



DIVERSIFIED STORAGE SYSTEMS
(888) SILO-SYS (888) 745-6797

PORTABLE Lo-Pro BATCHING SILO MANUAL



Legal 8'-6" Wide Legal 13'-6" Tall Overall Length is 26'



Portable Lo-Pro Batching Silo

- 800 CF. capacity (30 ton) ****Cement**
- Low-Profile design.
- 10" screw conveyor 12cu. ft. per minute discharge capacity.
- 10HP Electric Motor.
- Loss weight batching computer.
- Cone fluidizer system with distribution tank.
- 4- speed jacks.
- Overload protection with high level alarm.
- Other options available

***Cement can weigh between 88-94 lbs. per cubic foot depending on how aerated it is.*

1135 E. Wooley Rd. Ph # 805-247-0418
Oxnard CA, 93030 Fax # 805-247-0246

www.CementSilos.com



DIVERSIFIED STORAGE SYSTEMS
(888) SILO-SYS (888) 745-6797

PORTABLE Lo-Pro BATCHING SILO MANUAL

Portable Lo-Pro batching silo

The Standard DSS Low Profile Batching Silo is equipped with all the necessary equipment for operation. Electrical power to the panel and an air supply is all that is needed. The unique feature of this silo is its low profile design. A crane is not required to set up this unit in the field.

Be sure to keep the silo as moisture free as possible. Foreign objects or hardened cement will cause the auger system to jam. Clean out holes are installed in the auger to free jammed material. If the silo is not to be used for an extended length of time it should be cleaned out completely, as not to have hardened material dislodge into the auger system upon resumption of use. The auger system is designed to start under a full load, if some problem occurs jam gates are installed at the auger inlet points so material can be shut off from the auger in emergency situations. Keep the bearings greased (do not over grease) and check the lubricant level in the gear box, as it is not to run dry. Running dry will cause major damage to power transmission unit. Keep the auger discharge free of cement build up. Remove the boot sock occasionally and free any hardened materials. Neglect causes the drive to be over worked and could cause the motor to burn out.

The silo is equipped with a belle style dust collector. Be sure to check the dust socks for excess build up of cement. . The socks need to be checked to make sure they stay on the holders and the cleanout compartment cleaned out properly. Neglect may cause damage to the dust socks or possible damage to the silo. Care of these units depends on how much they are used.

The silo is equipped with an emergency pop-off valve. If the socks or air transfer system would plug, the valve would lift up relieving the pressure. The valve is adjusted by DSS but may need further adjusting on site. **DO NOT OVERTIGHTEN.** Do not over fill the silo. Over filling of this unit could cause a hazardous situation. The air transfer system will plug and the pop-off valve may also be rendered unable to function, causing the dust collector to break loose or the top to be forced open or possibly off. **BE CAREFUL NOT TO OVERFILL**

These instructions are a guideline to setting up a Diversified Storage System 800c.f. (200Brrl) lo-profile silo.

DO NOT FILL THE SILO WITH PRODUCT UNTILL THE SCALE HAS BEEN ENERGIZED AND CALIBRATED

Equipment Required:

1. Concrete pad or suitable foundation.

Specifications:

The size of the silo - the 200c.f. silo weights 12,000lbs empty , it is 8'-6" wide. It is 26' in length and 13'-6" tall.

1. There are four leveling jacks, one on each corner.
2. The foundation needs to be fairly level.

Foundation - The silo needs a suitable foundation able to withstand the weight of the silo fully loaded, that can be up to 88,000 lbs, depending on the product. It can be a concrete foundation or compacted dirt with steel freeway plates over top. Local building codes and soil condition need to be followed when deciding on the foundation. **It is the customers responsibility to determine the proper foundation.**



Use the leveling jacks on each corner to level the silo. The silo must be level for proper accuracy of the load cells.



DIVERSIFIED STORAGE SYSTEMS

(888) SILO-SYS (888) 745-6797

PORTABLE Lo-Pro BATCHING SILO MANUAL



Collector Specifications

Total Filtration Area	150 Sq. Ft.
Air to Cloth Ratio (ACFM/Sq.')	2.5
Pressure Drop (in. H 2O)	6"
Air Capacity	375 C.F.M.
Outlet Area (Sq.')	.58
Cleaning Method	Shaker Plate
Vibrator (Air or Electric)	Rotary Style
Vibrator Air Consumption (High Press.)	8 CFM (Max)
Vibrator Power	120 V/ 1 ph
Duty Cycle	1.5 hours
Normal Operating Pressure	8 - 15 PSI *
Max Operating Pressure	20 PSI *
Over pressure relief settings	18 PSI *

Filter Bag Specifications

Filter Bag Count	18 hung style
Replacement Filter Bag Model #	DC150S
Dimensions	8" OD X 48" Height
Filter Area (Per)	8.33 Sq. '
Material Weight	9 oz. / Sq. Yd.
Fiber	100% Polyester
Construction	Spun/Spun
Permeability	25 c.f.m.
Mullen Burst Dry	500 PSI
Temperature Limit	275 Deg. F.
Efficiency (PM-10)	99.99%

Vibrator Specifications

Air Vibrator	Model V-190
VPM @ 60 PSI	4200
CFM @ 60 PSI	7.5 CFM
Noise @ 60 PSI	70 db
Control	Manual
Electric Vibrator	Model 2P-75
Voltage/amps	115v/0.5 amp
VPM	3600
Noise	60 db.
Control	Auto/Manual

Collector Performance (PM-Reg.)**

0.0 - 0.5 Micron	99.98% Passing
0.5- 1.0 Micron	0.02 % Passing
1.0 - 20.0 Micron	0.0% Passing

** Typical Portland Cement is 44 Micron

Mounting Options

Bin Vent Mount (Silo Top)
Base Mount (Optional Base Needed)
Trailer Mount (Portable Applications)

* This style unit does not use magnahelic gauge. Dust Collector performance is measured by back pressure at load line.

1135 E. Wooley Rd. Ph # 805-247-0418
Oxnard CA, 93030 Fax # 805-247-0246

www.CementSilos.com



DIVERSIFIED STORAGE SYSTEMS

(888) SILO-SYS (888) 745-6797

PORTABLE Lo-Pro BATCHING SILO MANUAL

Monitor's line of rotary paddle bin monitors consists of the most reliable, rugged and economical point level control sensors available for detection of dry bulk materials. These easy to install units are proven performers in a wide variety of bulk materials. Monitor's paddle units can be used to eliminate bin overflow, maintain a predetermined material level, indicate plugging of conveyors and pneumatic lines or provide any of a number of level control functions. Unlike many other available paddle units, Monitor's paddle level indicators incorporate a feature that automatically shuts off the motor of the unit when the paddle is in a stalled position, which both extends the life of the motor and minimizes maintenance.

The operation of Monitor's paddle level control products is quite simple. The unit is installed through the wall of the vessel, so that the paddle protrudes inside the vessel. A small electric motor drives a paddle which rotates freely in the absence of material.

When the paddle is impeded by material, the motor rotates within the housing which triggers two switches. The first switch is a "dry" electrical contact closure that is available to control a process function or alarm circuit. The second switch cuts the power to the motor, preventing a locked rotor condition, thus extending motor life. This also activates the signaling device which is wired through that same motor switch. When the material level drops, the loaded stretched tension spring returns the motor to its original running position and the unit is reactivated.

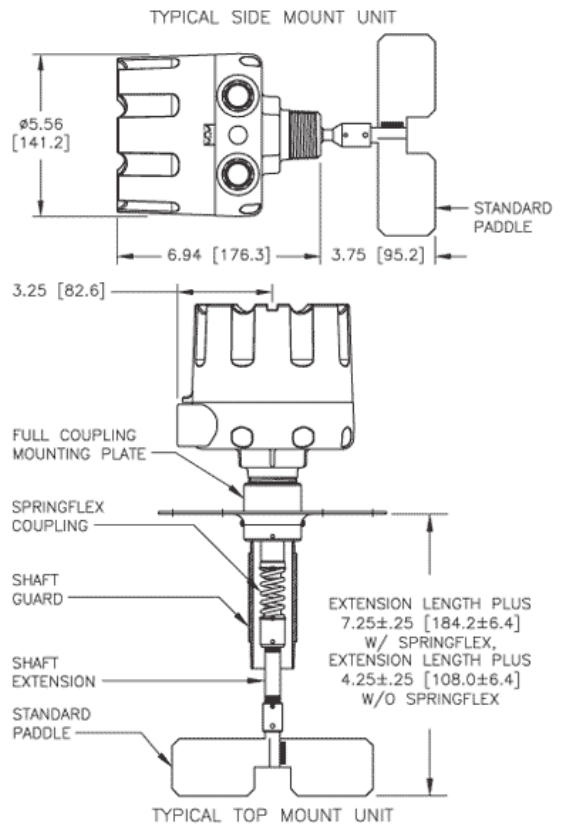

STD UNLESS SPECIFIED
XX" [XXmm]

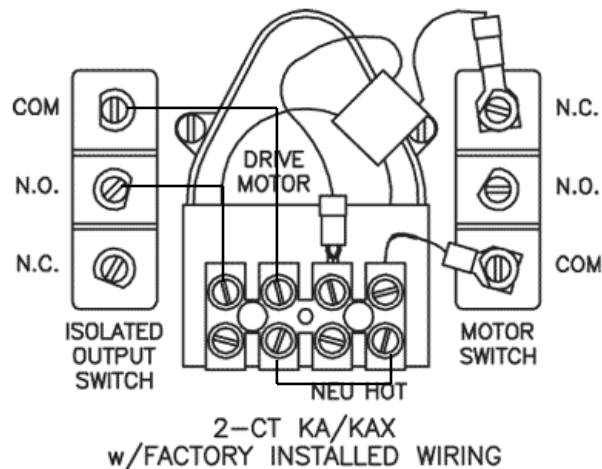

1135 E. Wooley Rd. Ph # 805-247-0418
Oxnard CA, 93030 Fax # 805-247-0246

www.CementSilos.com



DIVERSIFIED STORAGE SYSTEMS

(888) SILO-SYS (888) 745-6797

PORTABLE Lo-Pro BATCHING SILO MANUAL

Maintenance

Motor:

See Page 6-9

Your silo may be equipped with a Baldor, Lesson or World Wide Motor. Maintenance is the same on all.

Gear Box:

See Page 10-13

Your silo may be equipped with a Baldor, Lesson or Hub City gear box. Maintenance is the same on all.

Dust Collector:

The dust collector socks should get a visual inspection once a month. Check for excessive build-up on the socks. Make sure the vibrator is working. If the socks are clogged they should be replaced. The overflow compartment below the dust collector should be checked on a weekly basis and cleaned out as needed. The compartment should be no more than half full of material.

Auger:

Bottom bearing and lube block needs greased every 40 hours of use.

Top bearing needs to be greased every 200 hours of use

Filling the Silo:

Truck filling should not exceed 10-12 PSI. **DO NOT OVERFILL!**



DIVERSIFIED STORAGE SYSTEMS
 (888) SILO-SYS (888) 745-6797

PORTABLE Lo-Pro BATCHING SILO MANUAL

Maintenance Motor

Table 3-2 Service Conditions

Severity of Service	Hours per day of Operation	Ambient Temperature Maximum	Atmospheric Contamination
Standard	8	40° C	Clean, Little Corrosion
Severe	16 Plus	50° C	Moderate dirt, Corrosion
Extreme	16 Plus	>50° C* or Class H Insulation	Severe dirt, Abrasive dust, Corrosion, Heavy Shock or Vibration
Low Temperature		<-30° C **	

* Special high temperature grease is recommended (Dow Corning DC44). Note that Dow Corning DC44 grease does not mix with other grease types. Thoroughly clean bearing & cavity before adding grease.

** Special low temperature grease is recommended (Aeroshell 7).

Table 3-3 Lubrication Interval Multiplier

Severity of Service	Multiplier
Standard	1.0
Severe	0.5
Extreme	0.1
Low Temperature	1.0

Table 3-4 Bearings Sizes and Types

Frame Size NEMA (IEC)	Bearing Description (These are the "Large" bearings (Shaft End) in each frame size)					
	Bearing	OD D mm	Width B mm	Weight of Grease to add * oz (Grams)	Volume of grease to be added	
					in ³	tea- spoon
56 to 180 incl. (63 to 112)	6206	62	16	0.19 (5.0)	0.3	1.0
210 incl. (132)	6307	80	21	0.30 (8.4)	0.6	2.0
Over 210 to 280 incl. (180)	6311	120	29	0.61 (17)	1.2	3.9
Over 280 to 360 incl. (225)	6313	140	33	0.81 (23)	1.5	5.2
Over 360 to 449 incl. (280)	6319	200	45	2.12 (60)	4.1	13.4
Over 5000 to 5800 incl. (355)	6328	300	62	4.70 (130)	9.2	30.0
Over 360 to 449 incl. (280)	NU319	200	45	2.12 (60)	4.1	13.4
Over 5000 to 5800 incl. (355)	NU328	300	62	4.70 (130)	9.2	30.0
Spindle Motors						
76 Frame	6207	72	17	0.22 (6.1)	0.44	1.4
77 Frame	6210	90	20	0.32 (9.0)	0.64	2.1
80 Frame	6213	120	23	0.49 (14.0)	0.99	3.3

* Weight in grams = .005 DB

Note: Not all bearing sizes are listed. For intermediate bearing sizes, use the grease volume for the next larger size bearing.

1135 E. Wooley Rd. Ph # 805-247-0418
 Oxnard CA, 93030 Fax # 805-247-0246

www.CementSilos.com



DIVERSIFIED STORAGE SYSTEMS

(888) SILO-SYS (888) 745-6797

PORTABLE Lo-Pro BATCHING SILO MANUAL

Maintenance Motor

Lubrication Procedure

Be sure that the grease you are adding to the motor is compatible with the grease already in the motor. Consult your Baldor distributor or an authorized service center if a grease other than the recommended type is to be used.

Caution: To avoid damage to motor bearings, grease must be kept free of dirt. For an extremely dirty environment, contact your Baldor distributor or an authorized Baldor Service Center for additional information.

With Grease Outlet Plug

1. With the motor stopped, clean all grease fittings.
2. Remove grease outlet plug.

Caution: Overgreasing can cause excessive bearing temperatures, premature lubrication breakdown and bearing failure.

3. Add the recommended amount of grease.
4. Operate the motor for 15 minutes with grease plug removed. This allows excess grease to purge.
5. Re-install grease outlet plug.

Without Grease Provisions

Note: Only a Baldor authorized and UL or CSA certified service center can disassemble a UL/CSA listed explosion proof motor to maintain it's UL/CSA listing.

1. Disassemble the motor.
2. Add recommended amount of grease to bearing and bearing cavity. (Bearing should be about 1/3 full of grease and outboard bearing cavity should be about 1/2 full of grease.)
3. Assemble the motor.

Sample Lubrication Determination

Assume - NEMA 286T (IEC 180), 1750 RPM motor driving an exhaust fan in an ambient temperature of 43° C and the atmosphere is moderately corrosive.

1. Table 3-1 list 9500 hours for standard conditions.
2. Table 3-2 classifies severity of service as "Severe".
3. Table 3-3 lists a multiplier value of 0.5 for Severe conditions.
4. Table 3-4 shows that 1.2 in³ or 3.9 teaspoon of grease is to be added.

Note: Smaller bearings in size category may require reduced amounts of grease.

Maintenance Motor

Section 3 Maintenance & Troubleshooting

WARNING: UL rated motors must only be serviced by authorized Baldor Service Centers if these motors are to be returned to a flammable and/or explosive atmosphere.

General Inspection

Inspect the motor at regular intervals, approximately every 500 hours of operation or every 3 months, whichever occurs first. Keep the motor clean and the ventilation openings clear. The following steps should be performed at each inspection:

WARNING: Do not touch electrical connections before you first ensure that power has been disconnected. Electrical shock can cause serious or fatal injury. Only qualified personnel should attempt the installation, operation and maintenance of this equipment.

1. Check that the motor is clean. Check that the interior and exterior of the motor is free of dirt, oil, grease, water, etc. Oily vapor, paper pulp, textile lint, etc. can accumulate and block motor ventilation. If the motor is not properly ventilated, overheating can occur and cause early motor failure.
2. Use a "Megger" periodically to ensure that the integrity of the winding insulation has been maintained. Record the Megger readings. Immediately investigate any significant drop in insulation resistance.
3. Check all electrical connectors to be sure that they are tight.

Lubrication & Bearings

Bearing grease will lose its lubricating ability over time, not suddenly. The lubricating ability of a grease (over time) depends primarily on the type of grease, the size of the bearing, the speed at which the bearing operates and the severity of the operating conditions. Good results can be obtained if the following recommendations are used in your maintenance program.

Type of Grease

A high grade ball or roller bearing grease should be used. Recommended grease for standard service conditions is Polyrex EM (Exxon Mobil).

Equivalent and compatible greases include:

Texaco Polystar, Rykon Premium #2, Pennzoil Pen 2 Lube and Chevron SRI.

– Maximum operating temperature for standard motors = 110° C.

– Shut-down temperature in case of a malfunction = 115° C.

Lubrication Intervals

Recommended lubrication intervals are shown in Table 3-1. It is important to realize that the recommended intervals of Table 3-1 are based on average use.

Refer to additional information contained in Tables 3-2 and 3-3.

Table 3-1 Lubrication Intervals *

NEMA / (IEC) Frame Size	Rated Speed - RPM					
	10000	6000	3600	1800	1200	900
Up to 210 incl. (132)	**	2700 Hrs.	5500 Hrs.	12000 Hrs.	18000 Hrs.	22000 Hrs.
Over 210 to 280 incl. (180)		**	3600 Hrs.	9500 Hrs.	15000 Hrs.	18000 Hrs.
Over 280 to 360 incl. (225)			* 2200 Hrs.	7400 Hrs.	12000 Hrs.	15000 Hrs.
Over 360 to 5800 incl. (300)			*2200 Hrs.	3500 Hrs.	7400 Hrs.	10500 Hrs.

* Lubrication intervals are for ball bearings. For vertically mounted motors and roller bearings, divide the lubrication interval by 2.

** For motors operating in this speed range, contact Baldor for lubrication recommendations based on specific motor and application.



DIVERSIFIED STORAGE SYSTEMS

(888) SILO-SYS (888) 745-6797

PORTABLE Lo-Pro BATCHING SILO MANUAL

Maintenance Gear Box

APPROVED LUBRICANTS

HUB CITY GEAR LUBRICANT GL-90

(MOBILGEAR 630)

Part No. 8580001009

HUB CITY LUBRICANT	AGMA NUMBER	ISO-ASTM VISCOSITY GRADE
GL-90	5 EP	220

For Helical In-Line Gear Drives with ambient temperatures of 30-125° F (0-52° C) and operating temperatures to 185° F (85° C).

HUB CITY GL-90 LUBRICANT is a heavy duty industrial gear lubricant containing sulfur phosphorous antiwear additives. Lubricants of this general type and meeting the above specifications may be substituted where HUB CITY LUBRICANTS are recommended. Lubricant must be compatible with nitrile rubber seals. For ambient temperatures above 185° F (85° C) consult the factory.

HUB CITY ALL TEMPERATURE SYNTHETIC 75W-90 LUBRICANT (MOBILUBE SHC 75W-90)

Part No. 8580001031

HUB CITY SYNTHETIC 75W-90 LUBRICANT is a premium gear lubricant which is recommended for Helical In-Line Gear Drives in most applications, especially those subject to a low start up temperature and/or high operating temperature. This lubricant

is a synthesized hydrocarbon based material and a sulfur phosphorous gear lubricant additive which provides longer lubrication intervals because of its increased resistance to thermal and oxidative degradation. This decreases maintenance costs. Further economy is realized because of the increased efficiency of units lubricated with HUB CITY SYNTHETIC LUBRICANT. This lubricant can be operated at temperatures considerably above 185° F (85° C). However, the factory should always be contacted prior to operating at high temperatures as damage may occur to seals or other components. Lubricant manufacturer and HUB CITY should be contacted when substituting a premium lubricant where HUB CITY SYNTHETIC is recommended.

CAUTION

Do not mix nonsynthetic and synthetic oil in the unit.

CAUTION

If unit is used in the food or drug industry (including animal food) consult the petroleum supplier or HUB CITY for recommendation of lubricants which meet the specifications of FDA, USDA and/or other authoritative bodies having jurisdiction.

Standard lubricants are not suitable for these applications or these industries.

Approximate Oil Capacity (Pints) Double and Triple Reduction

Model Type	Mounting Position	UNIT SIZE (Foot or Flange Mount)									
		2032	2042	2043	2062	2063	2072	2073	2082	2083	2092
C-Frame or Gearmotor Models (HI20XXE) (HI220XXG)	B3, B5 Floor	Permanently Grease Lubed	1	2	1.6	4.1	5.1	8.1	7.6	13.7	16.9
	B8 Ceiling		1.8	2	3	4.2	7.4	7.6	11.4	11.8	20.1
	B6, B7 Wall		1.5	1.7	2.3	3	6.1	5.5	10.1	10.1	19.6
	V5, V1 Vertical		1.4	2.8	2.3	4.7	5.5	9.5	10	15.8	26.4
Shaft Input Models (HI20XXA) (HI20XXC)	B3, B5 Floor		1.9	2.6	3	4.9	7.5	9.1	11.8	15.4	26.2
	B8 Ceiling		2.2	2.2	3.1	4.3	7.8	8.6	13.2	12.9	23.3
	B6, B7 Wall		1.6	1.9	2.4	3.1	6.1	7.1	11	10.8	21.6
	V5, V1 Vertical		2.5	2.8	3.6	4.7	7.9	9.5	13.7	15.8	36.2

Approximate Oil Capacity (Pints) Quad Reduction

Quad reduction units are compound units, and the primary and secondary units are filled separately. Refer to the model table below and use the oil capacities in the table above.

Unit Size	2064	2074	2084
Primary Unit Size	2042	2062	2072
Secondary Unit Size	2062	2072	2082

(use primary oil capacities for desired Input type)
(use secondary oil capacities for C-Frame Input)

1135 E. Wooley Rd. Ph # 805-247-0418
Oxnard CA, 93030 Fax # 805-247-0246

www.CementSilos.com



DIVERSIFIED STORAGE SYSTEMS
 (888) SILO-SYS (888) 745-6797

PORTABLE Lo-Pro BATCHING SILO
MANUAL

Maintenance Gear Box

Mounting Positions, Fill, Level and Drain Locations.

FOOT MOUNT DOUBLE REDUCTION	
GEARMOTOR & MOTORIZED REDUCER	SHAFT INPUT
2042-2072 2082 B3 - Standard Floor	2082 2042-2072 B3 - Standard Floor
 B6 - LH Wall	 B6 - LH Wall
 B7 - RH Wall	 B7 - RH Wall
 B8 - Ceiling	 B8 - Ceiling
 V5 - Vertical Down	 V5 - Vertical Down

FOOT MOUNT TRIPLE REDUCTION	
GEARMOTOR & MOTORIZED REDUCER	SHAFT INPUT
2043-2073 2083 B3 - Standard Floor	2083 2043-2073 B3 - Standard Floor
 B6 - LH Wall	 B6 - LH Wall
 B7 - RH Wall	 B7 - RH Wall
 B8 - Ceiling	 B8 - Ceiling
 V5 - Vertical Down	 V5 - Vertical Down

BREATHERO

FILLER

FILLER/BREATHER

LEVEL

DRAIN

GREASE ZERK

1135 E. Wooley Rd.
 Oxnard CA, 93030

Ph # 805-247-0418
 Fax # 805-247-0246

www.CementSilos.com



DIVERSIFIED STORAGE SYSTEMS

(888) SILO-SYS (888) 745-6797

PORTABLE Lo-Pro BATCHING SILO MANUAL

Maintenance Gear Box

INSTALLATION INSTRUCTIONS FOR ELECTRIC MOTORS AND HYDRAULIC MOTORS AND PUMPS

Be sure all the paint and masking have been removed from the face and pilot of the flange. Check the input bore to be sure it contains an adequate amount of anti-seize compound which is normally installed at the factory. This compound will inhibit fretting corrosion between the motor or pump shaft and the unit bore.

Install the key (if round bore) to the maximum depth of the keyway provided in the bore.

Align keyways or splines of motor or pump and bore of unit and install motor or pump into flange. Do not use excessive force or pounding to install motor or pump into flange, as this may damage shafts or bearings.

CAUTION

HUB CITY "C" Flange Reducers and Hydraulic Flange Reducers are designed to accept motors with shaft lengths that do not exceed the maximum specified by the N.E.M.A. or SAE standards. If the motor or pump shaft bottoms out before the flange seats against the reducer flange face, the motor or pump shaft length must be adjusted to N.E.M.A. or SAE standards.

Secure the motor or pump to the unit. Capscrews and lockwashers are provided with "C" flange units.

Tightening torques for mounting bolts are provided in the chart below.

CAPSCREW TIGHTENING TORQUE Grade 5 Capscrews (dry, without lubricant)

Capscrew Size	Tightening Torque (Ft.-Lbs.)
---------------	---------------------------------

1/4 NC	8
5/16 NC	16
3/8 NC	29
1/2 NC	71
5/8 NC	143
3/4 NC	251



WARNING

Make certain that all tools and other items are clear from rotating parts before starting machine. Stand clear, and start machine slowly to be sure all components are secure and operating properly.

CAUTION

Test run unit to verify operation. If the unit being tested is a prototype, that unit must be of current production configuration.

PREVENTATIVE MAINTENANCE – Keep shafts and vent plug clean to prevent foreign particles from entering seals or gear case. Inspect periodically for oil leaks.

CAUTION

Mounting bolts, coupling fasteners, and other power transmitting devices should be routinely checked to ensure that all parts of the unit are firmly anchored to provide proper operation. (Loose fasteners can cause alignment problems and excessive wear). Check end play in shafts. Noticeable movement might indicate service or parts replacement.

IMPORTANT INFORMATION

In the event of the resale of any of the goods, in whatever form, resellers/buyers will include the following language in a conspicuous place and in a conspicuous manner in a written agreement covering such sale:

The manufacturer makes no warranty or representations, express or implied, by operation of law or otherwise, as to the merchantability or fitness for a particular purpose of the goods sold hereunder. Buyer acknowledges that it alone has determined that the goods purchased hereunder will suitably meet the requirements of their intended use. In no event will manufacturer be liable for consequential, incidental, or other damages.

Resellers/buyers agree to include this entire document, including the warnings and cautions listed herein, in a conspicuous place and in a conspicuous manner to instruct users on the safe usage of the product.

HUB CITY has Sales Offices and a network of Industrial Power Transmission Distributors that can serve your needs world wide. Check the Yellow Pages for one near you or contact the factory sales office.

A Parts List and Print for your Drive is available upon request. To obtain the proper Parts List and Print, you must accurately furnish the Assembly Number, Model Number, Ratio, Style and Shipping Code as shown on the metal tag attached to the Gear Drive. For assistance, phone or write your Industrial Power Transmission Distributor, or the Factory Sales Office.

1135 E. Wooley Rd. Ph # 805-247-0418
Oxnard CA, 93030 Fax # 805-247-0246

www.CementSilos.com



DIVERSIFIED STORAGE SYSTEMS

(888) SILO-SYS (888) 745-6797

PORTABLE Lo-Pro BATCHING SILO MANUAL

Maintenance Gear Box

CONGRATULATIONS...Your decision to purchase a Poweratio 2000 Helical In-line Gear Drive from HUB CITY will provide you with many years of trouble free service if the following lubrication and installation instructions are adhered to.

IMPORTANT

Read **ALL** instructions and safety precautions prior to operating unit. Injury to personnel or unit failure may be caused by improper installation, maintenance, or operation.

IMPORTANT SELECTION INFORMATION – Check to verify that the application does not exceed the capacities published in the current Helical In-line catalog, and printed on the gear unit name plate. All capacity ratings are based on proper application of AGMA Service Factors listed in the current catalog.

Written authorization from HUB CITY is required to operate or use gear units in man lift or people moving devices.

The system of connected rotating parts must be free from critical speed, torsional or other type vibration, regardless of how induced. The responsibility for this system analysis lies with the purchaser of the gear unit.

Buyer shall be solely responsible for determining the adequacy of the product for any and all uses to which the buyer shall apply the product. The application by buyer shall not be subject to any implied warranties of merchantability or fitness for a particular purpose.

LUBRICATION – All HUB CITY Helical In-line gearmotors and gear reducers are supplied with the correct quantity of lubricating oil for the mounting position specified at time of order.

CAUTION

BEFORE INSTALLATION – Review the approved mounting positions and lubrication levels identified on Pages 5-6. Do not deviate from the mounting positions or lubrication levels shown without contacting the factory.

For transportation the units are supplied as sealed gearcases. In place of the breather plug, a pipe plug is installed. The breather plug accompanies the unit in the lubrication instructions and hardware envelope.

BEFORE OPERATING – Install the breather plug in the location specified on Pages 5-6 for the appropriate mounting position.

QUAD REDUCTION UNITS – The primary and secondary units are independent units, with separate fill, vent, level and drain holes. Use the double reduction drawings on Pages 5-6 for the mounting positions and lube hole locations. The mounting position designation is based on the secondary unit, which can be foot mount or flange mount. The primary unit is always flange mount type.

CAUTION

Do not operate the unit without making sure it contains the correct amount of oil. The clear sight glass plug should be installed in

the proper oil level hole. The oil level is correct when the surface of the oil is at the center of the plug. When a solid plug is provided for the oil level, the oil level is correct when the surface of the oil is level with the lowest point of the level plug, shown on Pages 5-6, for the appropriate mounting position.

Do not overfill or underfill with oil, or injury to personnel, unit, or other equipment may result.

After installation, the actual mounting position should be confirmed against the mounting position shown on the gear reducer nameplate. Adequate lubrication is only guaranteed if the unit is mounted in the specific nameplated mounting position.

If the mounting position is changed, the oil quantity must be adjusted to obtain the specified oil level.

VARIATIONS FROM NORMAL CONDITIONS – Input speeds that exceed the maximum speeds recommended for a given ratio, which are listed in the general catalog specifications, may require an adjustment in the oil level. Consult HUB CITY for special lubricant recommendations when operating at higher speeds.

CHANGING LUBRICANT – After the first 100 hours of operation, drain out initial oil, flush out the gear case with an approved nonflammable, non-toxic solvent and refill. Thereafter, oil should be changed at least every 7500 operating hours (15,000 for synthetic oil lubricant) or every 18 months (24 months for synthetic oil lubricant) - whichever occurs first.

INPUT BEARING GREASE – The outer bearing on shaft input models is grease lubricated at the factory and sealed with a Nilos Ring for operation in all mounting positions. Pump 3 pumps of grease into the grease zerk after every 3,000 hours of operation, to lubricate the bearing and input seal.

CAUTION

Oil should be changed with greater frequency if unit is used in a severe environment such as dusty or humid.

CAUTION

If the unit cannot be located in a clear and dry area with an adequate cooling air supply, precautions must be taken to avoid ingestion of contaminants such as water, and to avoid a reduction of cooling ability due to exterior contaminants.



WARNING

Oil, housings, and other components can reach high temperatures during operation, and can cause severe burns. Use extreme care when removing lubrication plugs and vents while servicing the unit.

1135 E. Wooley Rd. Ph # 805-247-0418
Oxnard CA, 93030 Fax # 805-247-0246

www.CementSilos.com



DIVERSIFIED STORAGE SYSTEMS
 (888) SILO-SYS (888) 745-6797

PORTABLE Lo-Pro BATCHING SILO MANUAL

Dust Collector Timer



PROGRAMMABLE WALL SWITCH MODEL TI033A - SINGLE POLE FOR LIGHTS AND MOTORS

THE MAXIMUM LOAD MUST NOT EXCEED :

Resistive	20 A	Incandescent or halogen lighting, block heater, etc.
Inductive	20 A	Ballast equipped installations as : fluorescent or sodium lamp, etc.
Motor	1 HP	Pool filter, fan, etc.
Under 120 VAC / 60Hz		

INSTALLATION

WIRING DIAGRAM

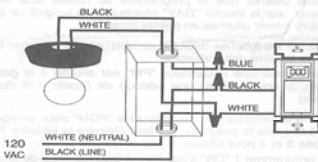

- 1 - Turn off the power at the circuit breaker to avoid electrical shock.
- 2 - Remove and disconnect the existing switch.
- 3 - Connect each wall switch lead to each circuit conductor as shown in above diagram.
- 4 - Restore power at circuit breaker.

POWER-ON

1. Lift up the bottom of the door using a small screwdriver.
2. Ensure that the ON/OFF switch is set to ON.
3. Press on the "RESET" button using a paper clip. On the display, 0:00 and MO should flash.

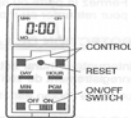

If there is nothing on the screen, test the following points :

- a) Maybe the ON/OFF switch located at lower part of the unit is not properly engaged in ON position. Push it to the right using a small screwdriver.
- b) If the wall switch controls a lamp equipped with an On/Off switch, care must be taken to keep the lamp switch in ON position.

SETTING TIME AND DAY

Before starting programming, you have to set the hour format (12 hour & 24 hour). You can change the time format anytime from 24 hrs. to 12 hrs. and back. To do so, maintain MIN key press down as HOUR key is pressed and released. Then, release MIN key.

1. Set the day by using the DAY key. If the current day is Tuesday, press and release DAY key until TU indicator appears on the lower area of the screen.
2. Set the time by using the HOUR and MIN keys. For the 12 hour time format, if you are setting an afternoon or evening time, make sure that the PM indicator is turned on at left side of the screen.
3. Close the door or press on one of the "CONTROL" keys to return to normal operation.

OPERATING MODES

The wall switch has 2 operating modes : the MANUAL and AUTOMATIC modes.

In the MANUAL mode, the wall switch is like any normal single pole switch. By pressing on the door, the user turns on and turns off the light. The display shows the MAN indicator as well as light state (ON or OFF).

The AUTOMATIC mode executes in sequence (hourly) the user's recorded programs. To place the wall switch in this mode, press on the door for 3 seconds until AUTO appears on the screen. The display shows the active program number and the light state (ON or OFF).

To override temporarily the programming, press on the MODE button. The overridden state indicator will flash to show that this state is temporary. The override remains in effect until overridden again or until the next program is reached.

RECORDING THE PROGRAMS

The memory of this wall switch can hold up to 7 programs. Each program consists of a time ON (turn on) and a time OFF (turn off) which can be run for a single day or for everyday of the week.

ATTENTION : Both ON and OFF programming sequences must be recorded.

1. Open the door of the wall switch using a small screwdriver.
2. Press on the PGM key.

The display will show the number 1 (program 1) on the lower right corner and the program state (ON/OFF) on the upper right corner. Note that the clock is replaced by -- : -- showing that the selected program is not activated.

3. Press on the DAY key to select the day to which you want the light to turn on.

If you want the program to be repeated each day of the week, keep pressing on DAY several times until every day of the week appears on the screen.

4. Press on the HOUR and MIN keys to set the time to which you want the light to turn on.

Make sure that PM indicator appears on the screen if you want an afternoon period (12 hour time format).

5. Press a second time on PGM key to set the time for the light to turn off. Repeat steps 3 and 4 to set the time.

If the program 1 ON is set for every day of the week, the program 1 OFF will automatically be set for every day.

6. To enter programs 2 to 7, repeat steps 2 to 5.

If you need only one program, just leave the others inactive. If you want to erase a program, select it by using the PGM key and then hold PGM key for 3 seconds. The program will be erased when the display will show -- : --.

7. Close the door or press on one of the "control" keys to return to normal operation.

MEMORY BACKUP

This wall switch is equipped with a rechargeable battery which will protect your programs during a power shut down. Note that the screen blanks during a power failure.

CHARACTERISTICS

Model : TI033A- SINGLE POLE
 Supply : 120 VAC, 50 / 60 Hz
 Load : 2400 watts resistive or inductive, 1 HP motor
 Approvals : CSA & UL
 Storage temperature range : -20 °C to 50 °C
 Operating temperature range : 0 °C to 50 °C

WARRANTY

AUBE TECHNOLOGIES INC. ONE YEAR LIMITED WARRANTY

This product is warranted against material defects and workmanship in normal use for a period of one year, from the date of the original purchase from authorized dealers. Warranty does not cover transportation costs. Nor does it cover a product subjected to misuse or accidental damage.

This limited warranty is in lieu of all other warranties, obligations or liabilities expressed or implied by the company. In no event shall AUBE technologies inc. be liable for consequential or incidental damages resulting from installation of this product. Within this period, any product proven defective in normal use will be repaired or replaced, at AUBE's option, without charge for either parts or labour, provided that the defective product with the original sale receipt is returned to the original dealer or is shipped pre-paid, insured and addressed to :

AUBE technologies Inc., 705 Montrichard, Saint-Jean-sur-Richelieu, (Quebec), Canada, J2X 5K8

Fax: (450) 358-4650
 service@aubetech.com
 www.aubetech.com

If you have any questions concerning the installation or the programming of the wall switch, please call our technical assistance at (450) 358-4600 for the Montreal area or 1-800-831-AUBE for outside area between 8:30 AM and 5:00 PM, Monday to Friday.

09/16/05 400-033-001-B

1135 E. Wooley Rd. Ph # 805-247-0418
 Oxnard CA, 93030 Fax # 805-247-0246

www.CementSilos.com



DIVERSIFIED STORAGE SYSTEMS

(888) SILO-SYS (888) 745-6797

*PORTABLE Lo-Pro BATCHING SILO
MANUAL*

Auger Details

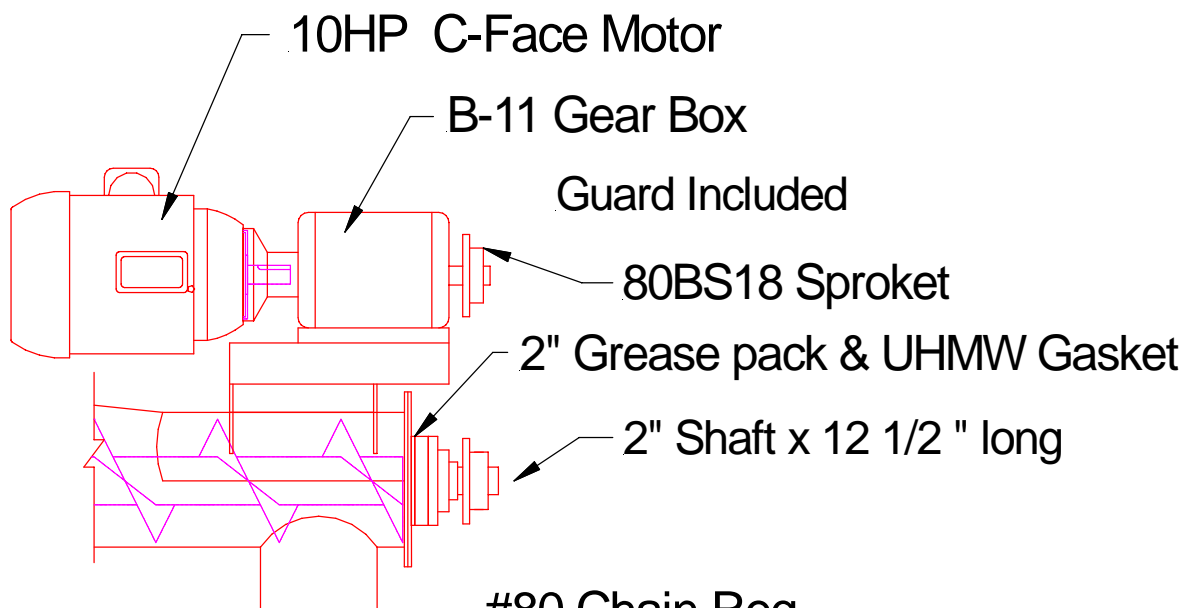

**#80 Chain Req.
27 Links + Master Link**

**Sprocket sizes vary depending on application.



DIVERSIFIED STORAGE SYSTEMS
(888) SILO-SYS (888) 745-6797

PORTABLE Lo-Pro BATCHING SILO MANUAL

Low Pro Silo 200-S

("Low Pro Silo 200-S" has 800 c.f. capacity)

Operating Instructions for silo with Rindstrom 411

First make sure scale head is reading zero, If not press tear.

To Run Discharge Auger Manually:

Turn **Hand/Off/Auto** (HOA) switch on panel to **Hand** position.

Checking Gross Weight in Hopper:

Press **SELECT** button on scale until the weight is displayed "Gross Indicator light on".
("Gross" is the weight of the product in the hopper.)

Setting Batch Weight:

Press **TARGET** button, (displays previous weight.)

Press **ENTER** button to keep weight, or

Key in new batch weight (i.e. 400), then press **ENTER**, (displays new batch weight)

Press **ENTER**.

Starting Batch Cycle:

Auto Mode:

Turn **Hand/Off/Auto** (HOA) switch on panel to **Auto** position.

At the Scale:

Start Batch Cycle - Press **START BUTTON**

(Note: there must be product in the hopper to start batch)

Pause Batch Cycle - Press **STOP** Button.

(To restart and finish batch cycle press **START** again, auger will stop at the end of the batch)

Abort Batch Cycle - Press **STOP** while auger is in the "Stop Mode" press **STOP** again to confirm.

Silo High Level Alarm:

Silo will hold approximately 63,000 lbs. gross weight of cement. (Lighter weight materials, the silo gross weight capacity will be less.)

If the silo becomes full, the **RED HIGH LEVEL LIGHT** and horn will turn on. If high level horn goes on, press the **GREEN HIGH LEVEL RESET BUTTON** on silo panel. This will shut off the horn. Have the truck driver stop until there is enough room to hold the rest of the load. If silo is full the **RED HIGH LEVEL LIGHT** will stay on.

Note: Check baghouse often to prevent overfilling and damage to filters. Replacement filters can be purchased from DSS (805) 247-0418 ex 25.

1135 E. Wooley Rd. Ph # 805-247-0418
Oxnard CA, 93030 Fax # 805-247-0246

www.CementSilos.com



DIVERSIFIED STORAGE SYSTEMS

(888) SILO-SYS (888) 745-6797

PORTABLE Lo-Pro BATCHING SILO MANUAL

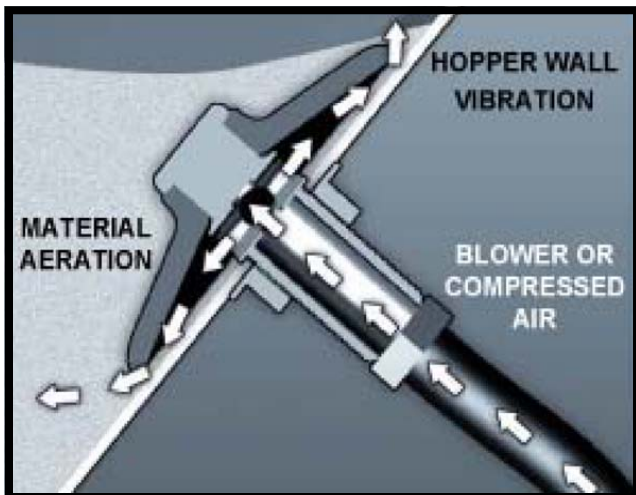

Aeration—loosens product allowing it to flow – minimum back pressure puts energy where it is needed the most – in the silo.

Directional Air Flow – forces air to move along the bin wall, freeing product, assuring good clean-out.

Gentle Vibration – keeps product flowing, without allowing it to compact or plug.

No Airline plugging— Disk seals tightly against the silo wall and prevents airline plugging.

Robust Design — Will not tear if cut, pick up moisture and is unaffected by temperatures up to 350° F (170° C) and up to 120 psi.

Material Compatible— Silicone rubber standard in blue or white (both food grade/FDA approved), or black or white EPDM.

BinFlow Specifications

Disk	4" Silicone Rubber
Stem	Mild Steel
Air Feed Fittings	1/4" or 1/2" NPT
Installation Hole	7/8"
Length of Stem	1 5/8"
Airline Options	3/8" - 1/2"
Capacity	10—20 CFM @ 20—30 PSI

BinFlo Applications

Silos, Bins, Hoppers, Rail Cars, Bulk Trailers

BinFlow Performance

Spacing Influence @ 20 PSI	24" from Each
Spacing Influence @ 30 PSI	36" from Each
Max PSI	120 PSI

1135 E. Wooley Rd. Ph # 805-247-0418
Oxnard CA, 93030 Fax # 805-247-0246

www.CementSilos.com



DIVERSIFIED STORAGE SYSTEMS

(888) SILO-SYS (888) 745-6797

PORTABLE Lo-Pro BATCHING SILO
MANUAL

Parts List

Standard Electric Drive

10hp/3ph/60hz 220/480v Electric Motor, C-face
Gear Box B-11
80BS24- x 1 1/2" Sprocket
80BS18 x 2" or 80BS24 x 2" Sprocket
#80 Chain
9" x 17" -0 Auger RH Flighting
2" x 12 1/2" Tail Shaft
Bearing pack - 2" 4 bolt
UHMW Block
Grease block 2"
Chain Tensioner

ELM 10W
DPG 10
DPS8024112
DPS80182 or 80242
DPCH80
DPAU1017R
DPAU112TS
DPB2
DPB2U
BPB25B
DPTSTE5

150sq. ft Dust Collector

Electric Vibrator 2p75
8" x 48" Polyester Sock (18) D-741-s

V110
FLBG-2

250sq. ft Dust Collector

Electric Vibrator 2p75
8" x 72" Polyester Sock (18) D-742-s

V110
FLBG-4

Additional Parts

Solimar Binflo Fluidizer 4300 (9)
Electric Vibrator on cone B3-500-1A-2
Monitor High Level Indicator KA 115
Foam Seal on 20" manway (top)
Foam Seal on Pressure relief valve
UHMW Block on Jam Gate
Rindstrom Scale
Load Cell

FU-1
VI-4
ELBN-2
SP3-5
SP-50
WAMUH
SC-RN411
SC30

Electrical Parts

Heaters (3)
600v 20A Mini Fuse
Midget TD Fuse 250v
Transformer 350VA
IEC Starter with overload relay
Programmable Automatic timer

ELH-9
ELF-4
ELF-10
ELTR-1
ELST-480I
ELRL-timer

Silo Serial # _____

Your parts may vary from above, Please have silo serial # available when ordering parts

Parts can be ordered through DSS at (888) 745-6797

1135 E. Wooley Rd. Ph # 805-247-0418
Oxnard CA, 93030 Fax # 805-247-0246

www.CementSilos.com



DIVERSIFIED STORAGE SYSTEMS
 (888) SILO-SYS (888) 745-6797

PORTABLE Lo-Pro BATCHING SILO MANUAL

ELECTRICAL PANEL

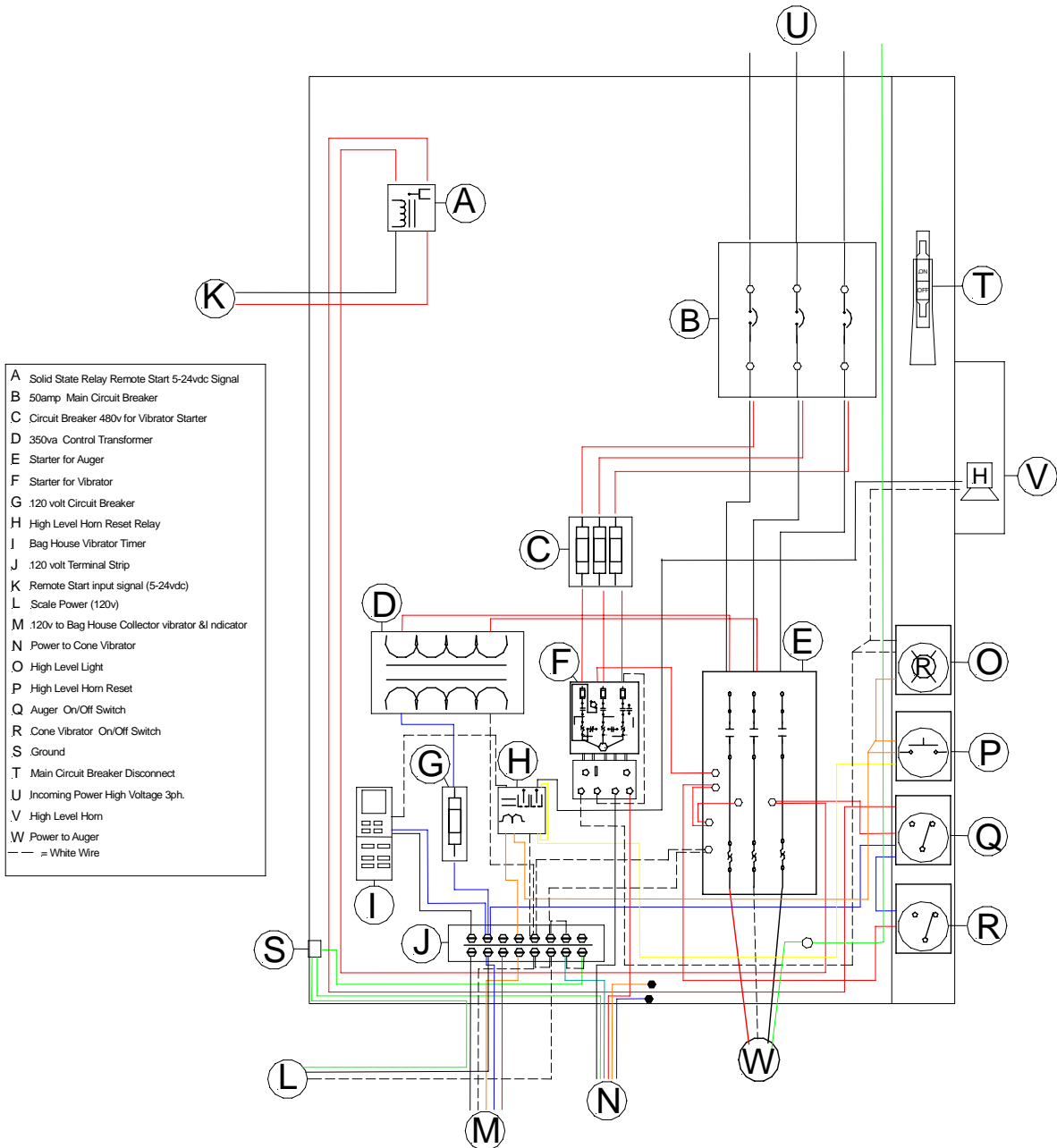

1135 E. Wooley Rd.
 Oxnard CA, 93030

Ph # 805-247-0418
 Fax # 805-247-0246

www.CementSilos.com