

LOW-PRO SILO - 800 CU. FT CAPACITY

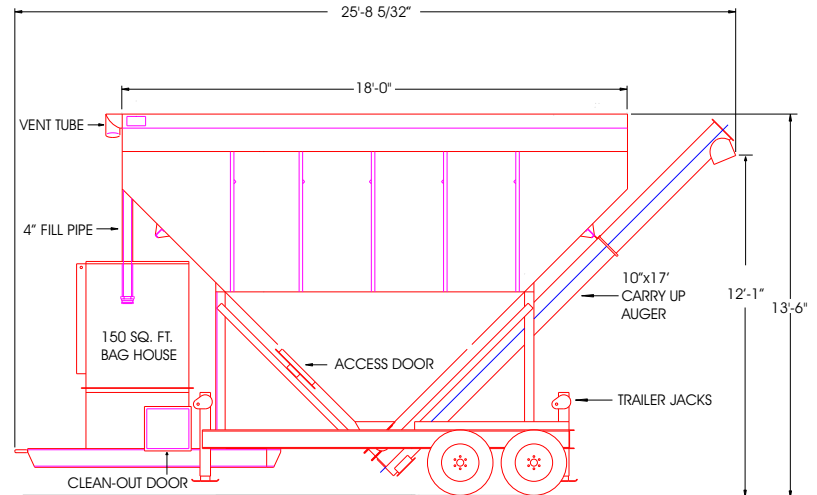

Can easily be towed - legal height & width!



STANDARD FEATURES

- 30 Ton Capacity (Cement)
- 10" Diameter Screw (12 cf/minute)
- 10hp 3 Phase Motor and Gear Box Drive
- 150 sq. ft. Bag House with Electric Vibrator
- Jamgate Assembly
- Upper Level Indicator with Light and Horn Alarm
- Starter Panel
- Cone Actuators
- Non-stick Cone Coating
- Heavy Duty Axle Trailer with Light Package

OPTIONS

- 7" Diameter Screw
- 5hp Motor and Gear Box Drive
- 16hp Gas Motor

SETUP/SITE REQUIREMENTS

- Compacted, level soil or better

APPLICATIONS

- Cement
- Fly Ash
- Lime
- CKD
- Sand
- Bentonite/Clay
- Calcium Carbonate
- Chemical Powder Products
- Agricultural Powder Products
- Food Grade Dry Bulk Products