

SMART WEIGHING SOLUTIONS



rinstrum

400 Series

(K411)

**Batching Indicator
Quick Start Manual**

004R-615-120

Copyright

All Rights Reserved. No part of this document may be copied, reproduced, republished, uploaded, posted, transmitted, distributed, stored in or introduced into a retrieval system in any form, or by any means (electronic, mechanical, photocopying, recording or otherwise) whatsoever without prior written permission of Rinstrum Pty Ltd.

Disclaimer

Rinstrum Pty Ltd reserves the right to make changes to the products contained in this manual in order to improve design, performance or reliability.

The information in this manual is believed to be accurate in all respects at the time of publication, but is subject to change without notice. Rinstrum Pty Ltd assumes no responsibility for any errors or omissions and disclaims responsibility for any consequences resulting from the use of the information provided herein.

Table of Contents

1. INTRODUCTION	3
1.1. Manuals	3
1.2. Shipping Contents	3
2. SPECIFICATIONS	4
3. INSTALLATION	5
3.1. Introduction	5
3.2. General Warnings	5
3.3. Panel Mount Template	6
3.4. Function Keys	6
3.5. Optical Communications	6
4. CONNECTIONS	7
4.1. Cable Connections	7
4.2. DC Power (DC PWR +, DC PWR –)	7
4.3. Load Cell Connection	7
4.4. Auxiliary Connections	9
4.5. Connecting Shields	11
4.6. Legal Sealing Details	12
5. INSTRUMENT SETUP	15
5.1. Accessing Full/Safe Setup	15
5.2. Exiting Full or Safe Setup	16
5.3. Using Menus	16
6. SETUP MENUS	17
6.1. GEN.OPT (General options)	17
6.2. H.WARE (Hardware Configuration & Test)	21
6.3. SCALE (Loadcell options and calibration)	24
6.4. FUNC (Special functions)	27
6.5. SER.NET (Network communications)	32
6.6. SER.AUT (Automatic transmit)	33
6.7. PRINT (Printouts)	34
6.8. SETP (Setpoints)	36
6.9. BATCH	38
6.10. ANL.OUT (Analogue Output)	47
6.11. End (Save and exit)	47
7. ACCESSORY MODULES	48
7.1. General	48
7.2. Installation and configuration	48
7.3. Input/Output Configuration	49

Quick Start - Software Version 1.x & 2.x

7.4.	Analogue Output	50
7.5.	Communications	50
8.	HARDWARE TESTING	52
8.1.	Overview	52
8.2.	Check Hardware Allocation.....	52
8.3.	Check Inputs	53
8.4.	Force Outputs	53
8.5.	Force Analogue Output.....	54
8.6.	Check Load Cell Hardware	54
9.	ERROR MESSAGES	55
9.1.	Overview	55
9.2.	Weighing Errors	55
9.3.	Setup Errors	56
9.4.	Calibration Errors	57
9.5.	Pause Conditions	58
9.6.	Diagnostic Errors	59

1. Introduction

This manual contains information on the installation, calibration and setup of the indicator.

1.1. Manuals

For more information on the indicator refer to the **Reference Manual** and **Operator Manual**.

1.2. Shipping Contents

The following table identifies the items shipped with indicators. Please check that your packing box contains the specified items.

Standard Indicator

- Digital Weighing Indicator
- Operator Manual
- Quick Start Manual
- Trade Label
- Panel Mount Template
- Function Key Overlay Stickers

Other Items (Optional)

There are optional accessories for this indicator, which include:

- Mounting options
- Power supply options
- Expansion modules (which supply additional communications ports, I/O, analogue output, etc).
- optoLINK temporary connection cable
- PC based configuration tool

2. Specifications

Performance	
Resolution	Up to 100,000 divisions, minimum of 0.25 μ V/division
Zero Cancellation	+/- 2.0mV/V
Span Adjustment	0.1mV/V to 3.0mV/V
Stability/Drift	Zero: < 0.15 μ V/ $^{\circ}$ C (+ 10ppm of deadload max) Span < 10 ppm/ $^{\circ}$ C, Linearity < 20ppm, Noise < 0.2 μ Vp-p
Excitation	7.4 volts for up to 16 x 350 or 32 x 700 ohm load cells (4-wire or 6-wire plus shield) Maximum total load cell resistance: 1,000 ohms
A/D Type	24bit Sigma Delta with \pm 8,388,608 internal counts
Operating Environment	Temperature: -10 to +50 $^{\circ}$ C ambient Humidity: <90% non-condensing Storage: -20 to +50 $^{\circ}$ C ambient IP65 when panel mounted or with rear boot (otherwise IP40)
Case Materials	ABS, Silicon Rubber, Nylon, Acrylic (no halogen used)
Packing Weights	Basic Indicator: 0.7kg
Digital	
Display	LCD with 4 alpha-numeric displays and LED backlighting: Primary display: 6 x 28.4mm high digits with units and annunciators 2 nd display: 9 x 17.6 mm digits with units 3 rd display: 8 x 6.1 mm digits 4 th display: 4 x 7.6 mm digits
Setup and Calibration	Full digital with visual prompting in plain messages
Digital Filter	Sliding window average from 0.1 to 30.0 seconds
Zero Range	Adjustable from +/- 2% to +/- 20% of full capacity
Power Input	
Standard Power Input	12 to 24VDC (15 VA max) - ON/OFF key with memory feature
Variants	
M4101 AC	AC power supply Input: 110/240VAC 50/60Hz Output: 12VDC 15VA
M4102 Battery	2.5AH NiMH rechargeable battery pack Charger Input: 110/240VAC 50/60Hz Output: 12VDC
Features	
Optical Data Communications	Magnetically coupled optical communications support. Optional conversion cable connects directly to a standard USB or RS-232 port.
Correction	10 point linearity correction
Serial Outputs	RS-232 serial port for remote display, network or printer supports. RS-485 transmit only for remote display Transmission rate: 2400, 4800, 9600, 19200 or 57600 baud
3 assignable function keys	Printing, unit switching, counting, manual hold, peak hold and totalizing
Battery Backed Clock Calendar	Battery life 10 years minimum
Approvals	FCC, CE, C-tick, Check trade approvals

3. Installation

3.1. Introduction

The following steps are required to set up the indicator.

- Inspect indicator to ensure good condition.
- Use connection diagrams to wire up load cell, power and auxiliary cables as required.
- Use the drilling template provided for hole locations.
- Connect Power to indicator and press **<POWER>** key to turn the instrument ON.
- Refer to the Instrument Setup section page 15 for information on configuring and calibrating the instrument.
- To turn instrument OFF press and hold **<POWER>** key for three seconds (until display blanks).

3.2. General Warnings

- Indicator not to be subject to shock, excessive vibration or extremes of temperature (before or after installation).
- Inputs are protected against electrical interference, but excessive levels of electro-magnetic radiation and RFI may affect the accuracy and stability.
- For full EMC or for RFI immunity, termination of cable shields and correct earthing of the instrument is essential.
- Indicator and load cell cable are sensitive to excessive electrical noise. Install well clear of any power or switching circuits.

3.2.1. Electrical Safety

- For your protection all mains electrical hardware must be rated for environmental conditions of use.
- Pluggable equipment must be installed near an easily accessible power socket outlet.

- To avoid the possibility of electric shock or damage to the instrument, always switch off or isolate the instrument from the power supply before maintenance is carried out.

3.3. Panel Mount Template

The panel mount template is supplied with the instrument. It shows the location of the rectangular cut-out and the four mounting screws.

3.4. Function Keys

- The indicator has 3 user definable functions keys.
- Special function overlay stickers are supplied. Affix to matching special function key if used.
- Ensure keypad is clean and dry before affixing sticker.

3.5. Optical Communications

A temporary infrared communications link can be established between the instrument and a PC using an optional opto-link cable. This connection can be used to transfer setup and calibration information from a PC or to download indicator software upgrades.

The PC end of the cable is a standard female DB9 RS232 or USB connector. The instrument end of the cable attaches to the left side of the instrument display.

WARNING

The optical coupling head contains a strong magnet and should not be placed near any magnetic storage media (e.g. credit cards, floppy disks etc.)

4. Connections

4.1. Cable Connections

All cable connections are made to the rear of the instrument using pluggable screw terminals. It is not necessary to tin the ends of the wires with solder or to add crimp ferrules to the wires, but these techniques are compatible with the terminals.

LOAD CELL CONNECTIONS

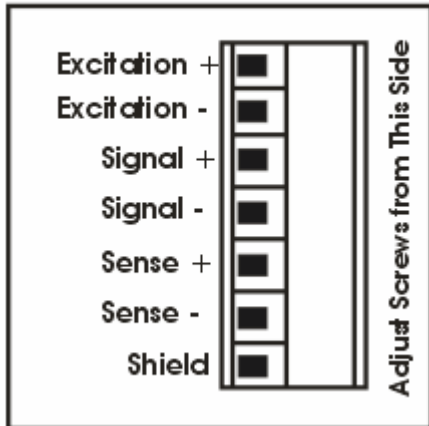

COMMS CONNECTIONS

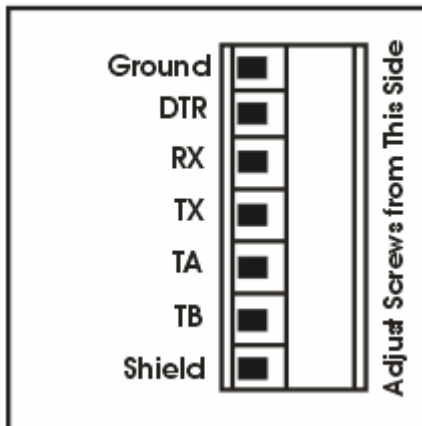

4.2. DC Power (DC PWR +, DC PWR -)

The DC supply need not be regulated, provided that it is free of excessive electrical noise and sudden transients. The instrument can be operated from a high quality plug-pack as long as there is sufficient capacity to drive both it and the load cells.

4.3. Load Cell Connection

4.3.1. Load Cell Signals

Very low output scale bases may be used but may induce some instability in the weight readings when used with higher resolutions. Generally speaking, the higher the output, or the lower the number of divisions, the greater the display stability and accuracy.

The instrument can display the mV/V reading (H.WARE:LC.HW:MOV) which can be used to check scale base signal output levels. The instrument may be connected for either 4-wire or 6-wire operation. Use 4-wire when external SENSE connections are not available.

4.3.2. 4-Wire Connection

The minimum connectivity requirements are the connection of four wires (i.e. \pm Excitation and \pm Signal). Internally the instrument has a precision analogue switch that can be used to connect the Sense+ and Sense- lines directly to the Excitation+ and Excitation- lines.

Any addition to the load cell manufacturer's cable length using 4-wire connection is only recommended for short cable runs. Where long additions to cable lengths are needed, a 6-wire extension is required.

The SCALE:BUILD:CABLE option must be set to **4-WIRE** to allow for 4-wire connection.

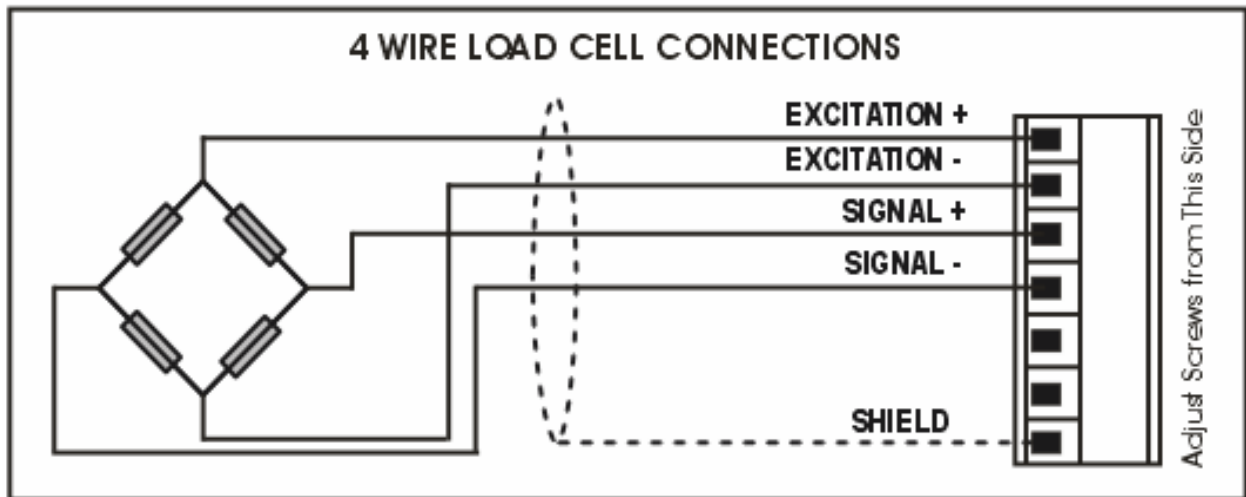

4.3.3. 6-Wire Connection

The excitation and signal lines are connected the same as for a 4-wire installation. The extra two wires (Sense + and –) should be connected to the Excitation + and – lines as close as possible to the load cell itself. Typically these connections are made in a load cell termination box.

The BUILD:CABLE option must be set to **6-WIRE** to allow for true 6-wire connection.

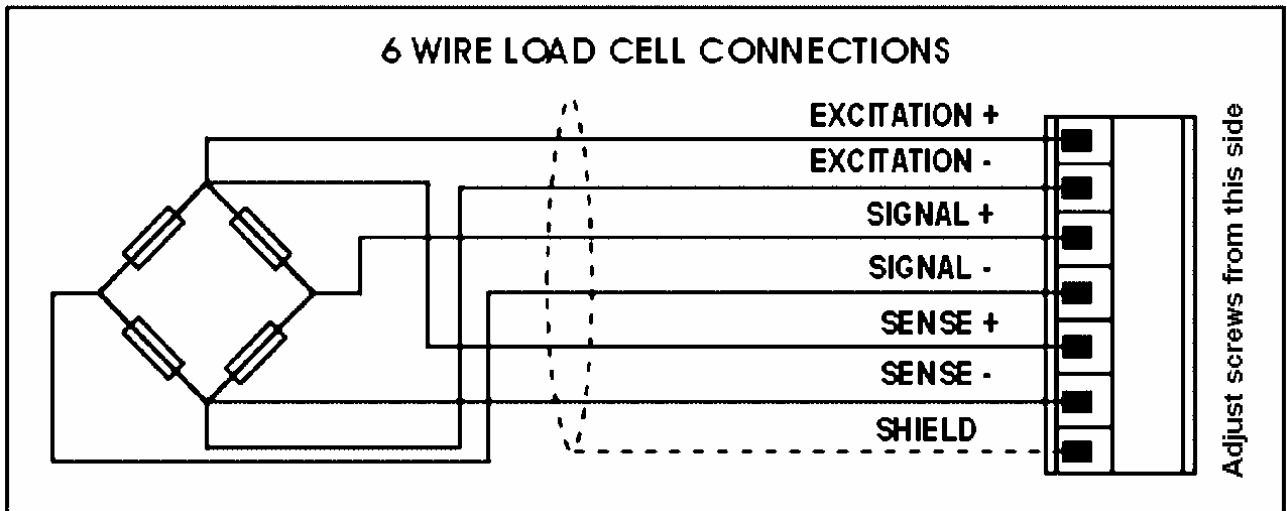

4.4. Auxiliary Connections

This section provides diagrams to illustrate the communication connections.

4.4.1. Direct Personal Computer Link (RX, TX GND)

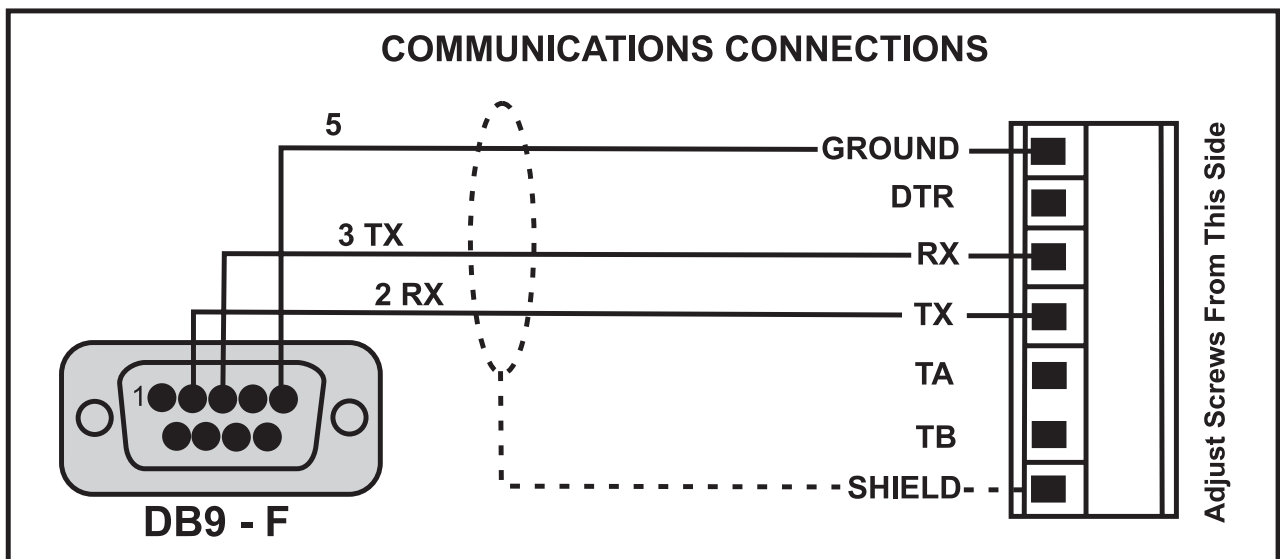

4.4.2. Printer Connections (RXD/TXD, GND and DTR)

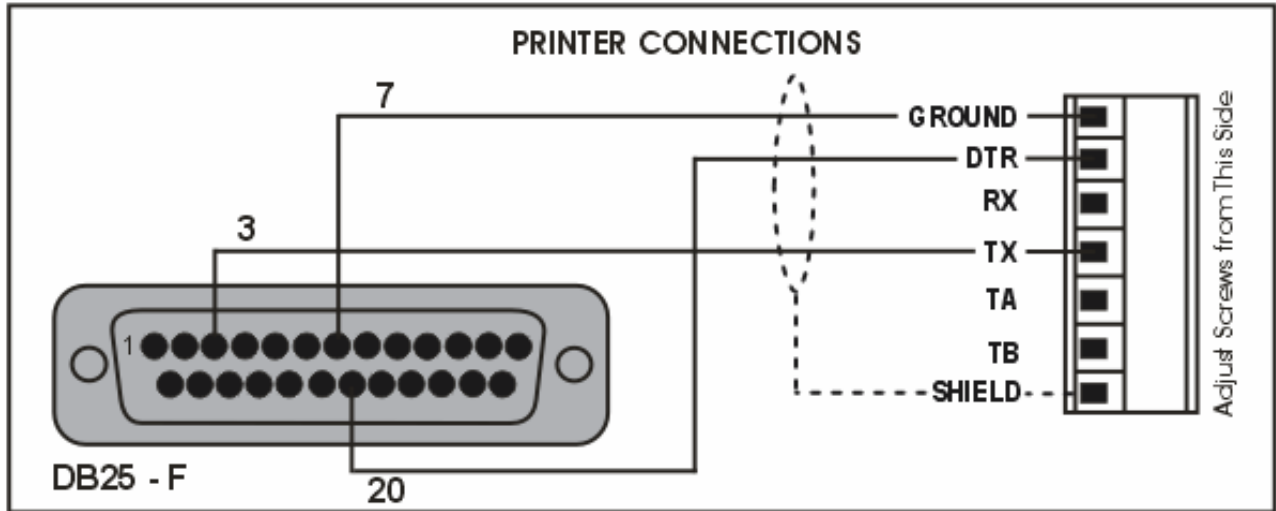

4.4.3. Remote Display using RS232 (TXD, GND)

Refer to documentation supplied with the Remote Display for connection details. Connect RX on the Remote Display with TX on the instrument and connect the RS232 GND signals together.

4.4.4. Remote Display using RS485 (TA, TB)

RS485 is recommended for communicating over distances longer than a few metres. Refer to documentation supplied with the Remote Display for connection details. Connect TA to RA and TB to RB.

4.5. Connecting Shields

To obtain full EMC or for RFI immunity, cable shields MUST be connected and the earth lug on the rear of the instrument must be grounded.

This figure illustrates an example of possible connections. Also shown are the connecting cables restrained using cable ties fastened by screws into the rear of the unit.

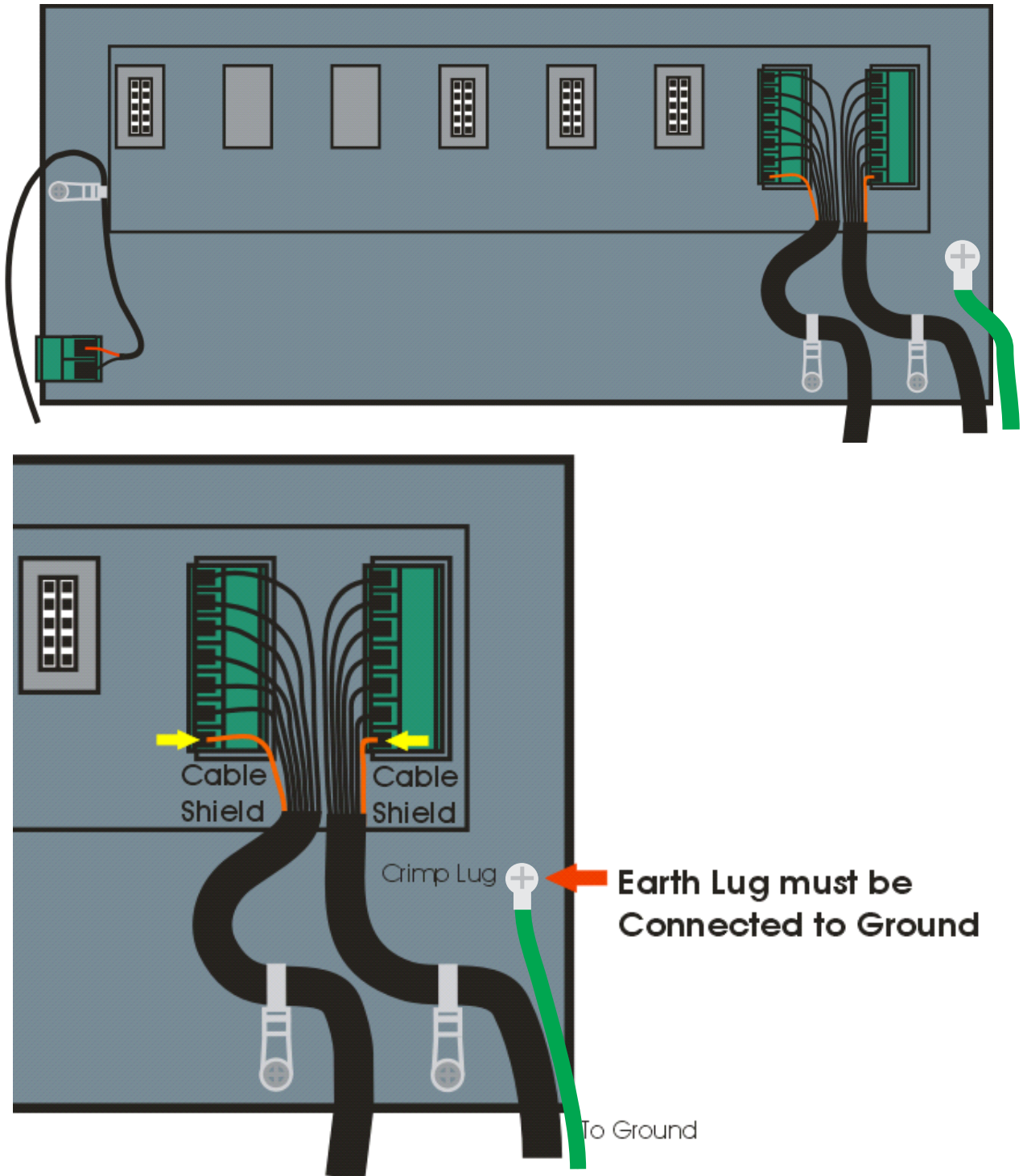

4.5.1. Cable Shield Connection and Earthing

- Care should be taken when connecting shields to maximise EMC or RFI immunity and minimise earth loops and cross-talk (interference) between instruments.
- For full EMC or for RFI immunity, termination of the cable shields at the earth lug is very important. The earth lug of the instrument must be separately connected to ground potential via a reliable link.
- The AC power module directly connects the earth lug to the Earth Pin on the power supply. In installations where earth is available on the power cable, instrument earthing can be done with this connection.
- The instrument should only be connected to earth via a single reliable link to avoid earth loops.
- Where each instrument is separately earthed, interconnecting cable shields should be connected at one end only.
- **Caution:** Some load cells connect the cable shield directly to the load cell (and therefore the scale base). Connection of the load cell cable shield may be site specific.

4.6. Legal Sealing Details

There are several methods of legally sealing the instrument. The method chosen will depend on local regulations.

4.6.1. Trade Label and Electronic Seal

For trade-certified applications, a tamperproof certification label can be placed on the front of the instrument to provide an electronic seal. The instrument has a built-in calibration

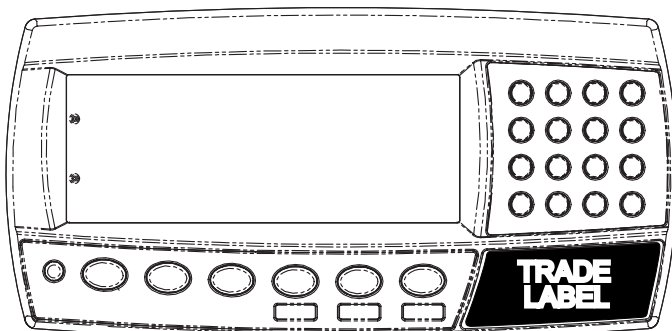

counter to monitor when critical settings are altered. The value of the calibration counter should be written on the certification label.

4.6.2. Lead Seals

There are 2 methods of sealing the instrument with lead and wire seals:

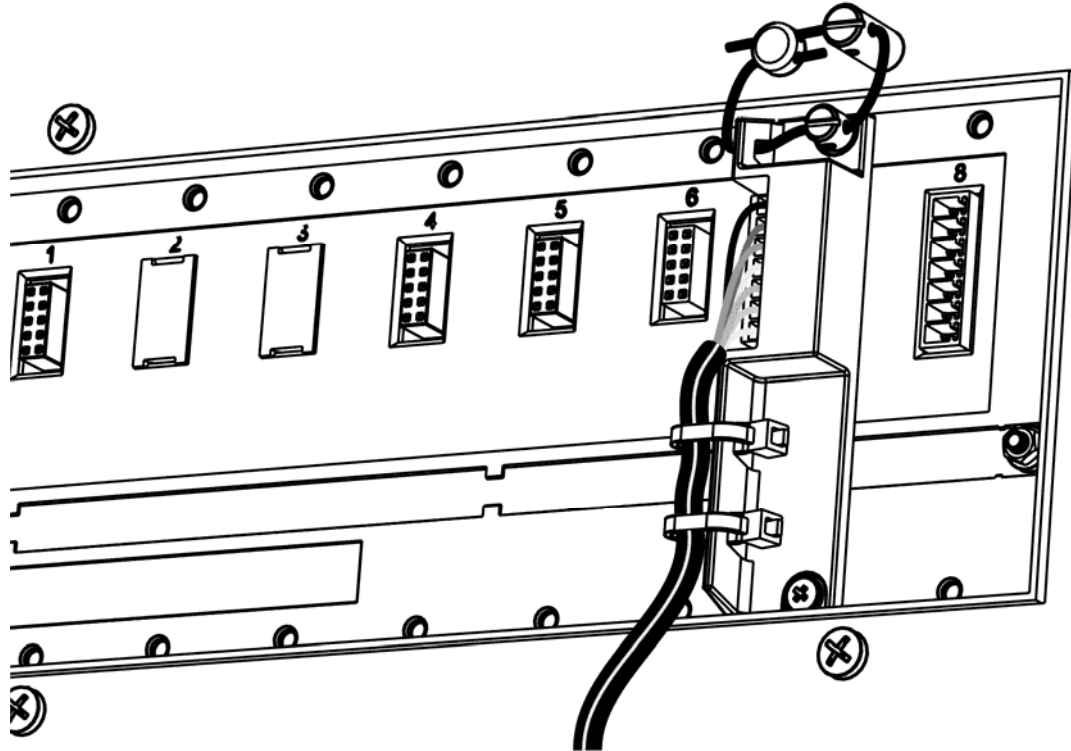

Figure 1: Lead seal on rear of instrument.

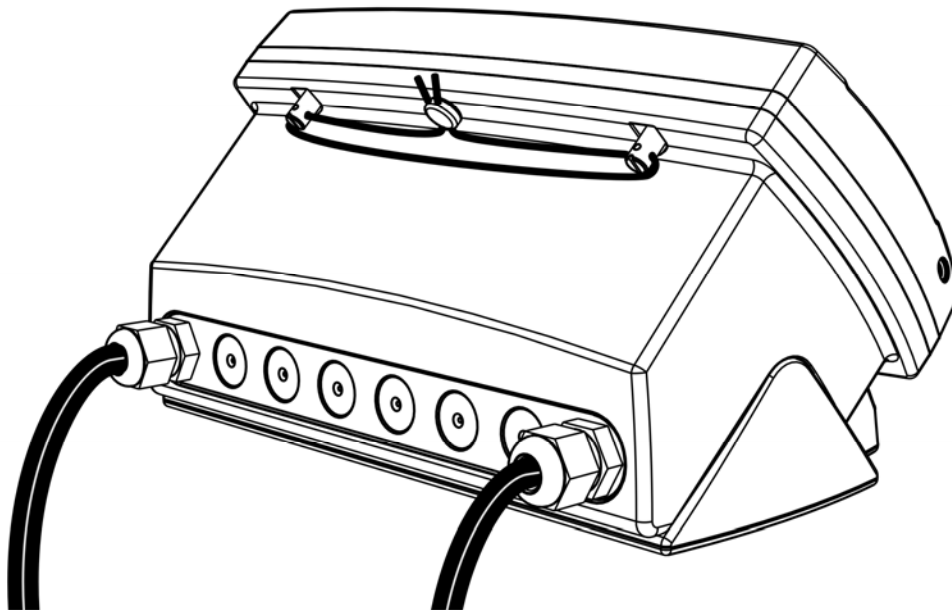

Figure 2: Lead seal on boot.

4.6.3. Destructible Sticker Seals

There are 2 methods of sealing with destructible stickers:

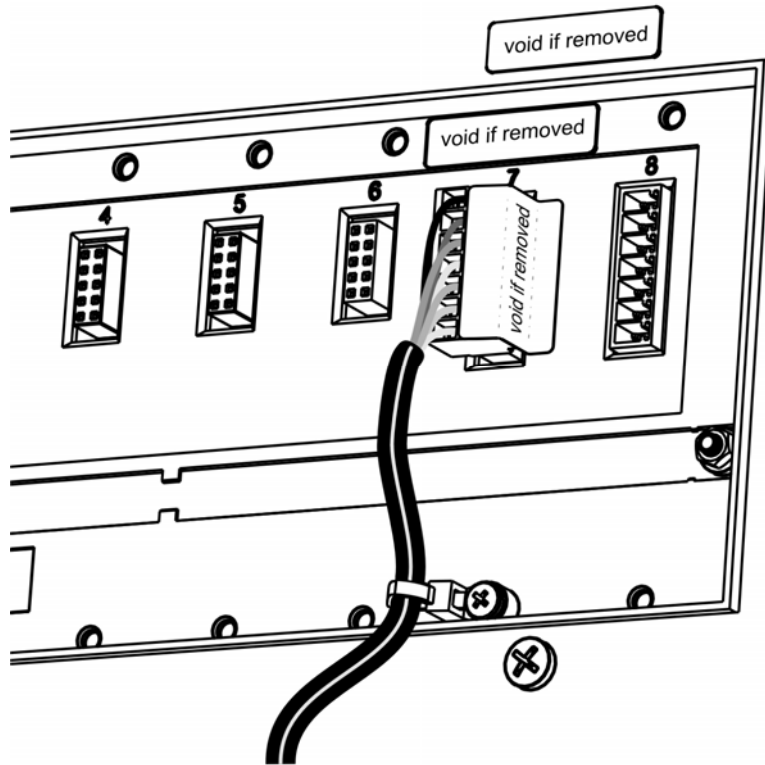

Figure 3: Destructible sticker seal on rear of instrument.

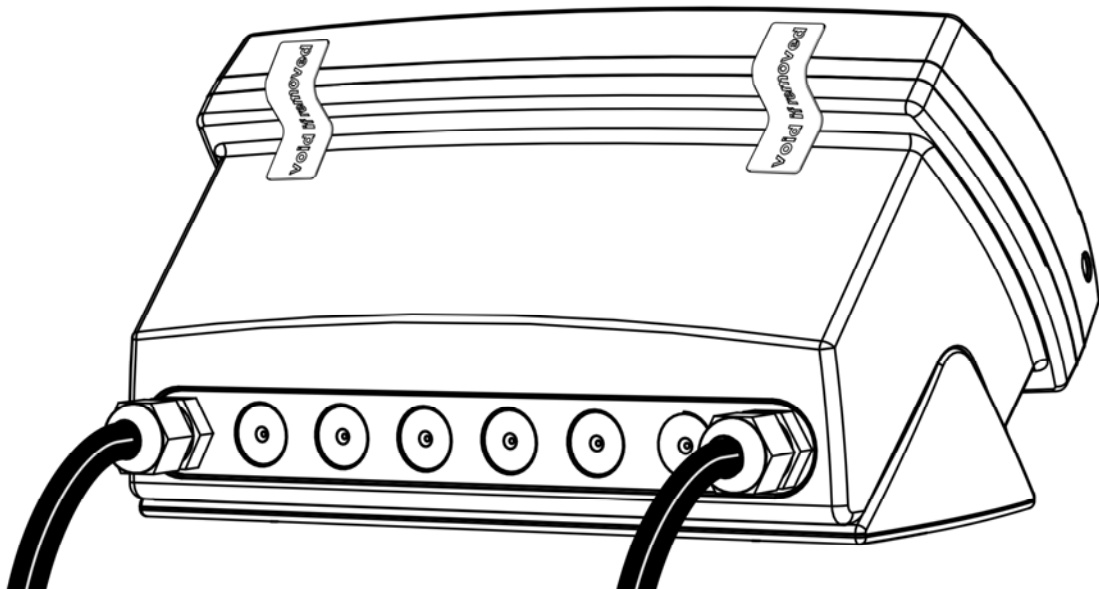

Figure 4: Destructible sticker seal on boot.

5. Instrument Setup

5.1. Accessing Full/Safe Setup

When **Full Setup** is used, all menu items are accessible, including legal for trade and calibration sensitive settings, and care must be taken to ensure no accidental changes are made to calibration and trade settings. The **Safe Setup** method restricts access to the Trade Critical settings.

WARNING

All items in all menus will be enabled in **Full Setup**. Care should be taken to avoid inadvertently altering the Build or Calibration settings.

Full Setup



To access **Full Setup**, first ensure the instrument is on. Then press and hold both the **<POWER>** and **<F3>** keys together for two seconds.

Safe Setup



To access **Safe Setup**, first ensure the instrument is on. Then press and hold both the **<POWER>** and **<ZERO>** keys together for two seconds.

Full and Safe Setup can be passcode protected to prevent unauthorised or accidental tampering. If the passcode is lost, the manufacturer should be contacted for further advice.

5.2. Exiting Full or Safe Setup

To save settings, exit setup and return to the normal weighing mode using one of the following methods:

Method 1: Press the **<POWER>** key.

Method 2: Press the **<ZERO>** key repeatedly. When END displays press **<TARE>**.

If the power is interrupted while in setup (i.e. by disconnecting the power cable), unsaved settings will be lost.

5.3. Using Menus



Level 1



Level 2



Level 3



Level 4



Level 5

Example:

GEN.OPT

 L PCODE

 L SAFE.PC

6. Setup Menus

6.1. GEN.OPT (General options)

DATE.F (Date format)

Path	Description
GEN.OPT L DATE.F	Sets the date format
DATE.F Values <OPT>	
DD.MM.YYYY (Default) , DD.MM.YYYY, MM.DD.YY MM.DD.YYYY, YY.MM.DD, YYYY.MM.DD	

PCODE (Security passcodes)

Path	Description
GEN.OPT L PCODE L SAFE.PC L FULL.PC (*) L OP.PC	Sets the instrument passcodes. The three levels of passcode are: Full passcode (FULL.PC): Controls access to full setup menus. All settings (including trade critical settings) can be altered from full setup. The full passcode will also give access to safe or operator functions. Safe passcode (SAFE.PC): Controls access to safe setup menus. No trade critical settings can be altered from safe setup. The safe passcode also gives access to operator functions as defined by Key Lock. Operator passcode (OP.PC): Controls access to operator functions, as defined by Key Lock.
(*) Available in FULL SETUP only PCODE Values <NUM> 0 (Default) .. 999999	
Note: A passcode value of 0 deactivates the passcode.	

KEY.LOC (Key Function Access Control)

Path	Description
GEN.OPT L KEY.LOC L P(*) L ZERO L TARE L RECIPE L F1 L F2 L F3 L CLOCK L VIEW L REPORT L TOTAL L ID L TARGET L ACC L PR.MOD L PR.SEL L NUM.PAD L ALIBI L RECIPE L FLIGHT L TOL L TIMERS	<p>Access to each of the operator functions can be configured separately as either:</p> <p>AVAIL: function always available</p> <p>OPER.PC: requires a valid Operator Passcode</p> <p>SAFE.PC: requires a valid Safe Passcode</p> <p>LOCKED: function never available</p> <p>Functions protected with a 'Safe' passcode prompt for the passcode every time.</p> <p>Entering the Operator Passcode unlocks all operator protected functions so the operator is not continually prompted for the passcode. In order to lock the instrument again press the '.' key for two seconds (function 'Lock').</p>
KEY.LOC Values <OPT>	
AVAIL*, OPER.PC, SAFE.PC, LOCKED* (*) only are available for POWER.	

DISP (Display options)

Path	Description
GEN.OPT L DISP L B.LIGHT L FREQ L AUX.DSP L LAYOUT	These settings control the operation of the display. B.LIGHT (Backlight operation) FREQ (Frequency) display update rate. AUX.DSP (Auxiliary Display):
B.LIGHT Values <OPT>	TIME: to show the current instrument time.
ON ^(Default) , OFF	PRODUCT: current product number.
FREQ Values <OPT>	STAGE: current batching stage number.
1, 2, 3.3, 5, 10 ^(Default) Hz	BAT.NUM: shows current batch number
AUX.DSP Values <OPT>	BAT.LEFT: shows remaining number of batches
OFF ^(Default) , TIME, PRODUCT, STAGE, BAT.NUM, BAT.LEFT, NUM.ITEMS	NUM.ITEMS: shows the number of items that have been added to totals
LAYOUT Values <OPT>	LAYOUT (Display Layout): selects the default view displayed when the instrument powers up. The operator can select alternative views by a long press of the '2' key (function 'View').
PRODUCT ^(Default) , TOP	PRODUCT: information displayed on both displays. TOP: only the Primary Display is shown. The Secondary Display can be used to show operator prompts received from the communications.

ID.NAME (ID name strings)

Path	Description
GEN.OPT L ID.NAME L NAME.1 L NAME.2 L NAME.3	There are three IDs available to the operator, long press of the '5' key (function 'ID'). NAME.1, NAME.2 and NAME.3 specify the actual prompts displayed for the operator. (eg. to allow the operator to enter a Customer ID, NAME.1 could be set to 'CUST'.)
Values <STR>	To remove an ID from the operator menu give it an empty name.
Max 6 characters	

POWER (Power options)

Path	Description
GEN.OPT L POWER L AUT.OFF L START	AUT.OFF (Auto-off delay) Sets the automatic power off setting. The instrument will switch off after set minutes of inactivity. NEVER disables the auto power off feature.
AUT.OFF Values <OPT>	
NEVER ^(Default) 1, 5, 10, 60 min	START (Pause at Start-up) If ON the START function forces the instrument to pause on power up and prompt the operator to continue. This ensures that restarting the instrument does not go unnoticed.
START Values <OPT>	
OFF ^(Default) , ON	

USR.DEF (Set all non-calibration settings to defaults)

Path	Description
GEN.OPT L USER.DEF	Sets all general instrument settings to defaults.
Values	This will not affect settings in the SCALE menu which includes all calibration and configuration settings.
DEFAULT? <OK>	
CONFIRM? <OK>	

6.2. H.WARE (Hardware Configuration & Test)

ALLOC (Allocation Report)

Path	Description
H.WARE	Check hardware allocation.
└ ALLOC	<p>Displays the function of each item of hardware. Items of hardware include serial ports, function keys, inputs and outputs.</p> <p>Use the UP and DOWN arrows to step through the hardware.</p> <p>Use the +/- key to step through the available information for each item of hardware.</p> <p>Errors: If a single item of hardware has been assigned to 2 or more functions, an error message is shown. "CHECK" is used if it is possible that the setup is OK. "CLASH" is shown if it is likely a setup error.</p>

LC.HW

Path	Description
H.WARE	MVV: View Loadcell mV/V reading.
└ LC.HW	<p>OL.CNT (Overload count): Shows the number of times the instrument has been overloaded or underloaded by at least 50% of fullscale.</p> <p>OL.CLR (Overload clear): Clear the overload counter.</p>
└ MVV	
└ OL.CNT	
└ OL.CLR	

SER1.HW, SER2.HW

Path	Description
H.WARE	BAUD (Baud Rate)
L SER1.HW	Sets the baud rate for the port.
L BAUD	
L PARITY	PARITY
L DATA	Sets the parity for the port.
L STOP	DATA (Data bits)
L DTR	Sets the number of data bits for the port.
L TERM	
L SER2.HW	STOP (Stop bits)
L BAUD	Sets the number of stop bits for the port.
L PARITY	
L DATA	DTR (DTR usage)
L STOP	Use the DTR line with RS232 printing.
L DTR	TERM (Termination Resistors)
L TERM	Use termination resistors with RS485.
BAUD Values <OPT>	
2400 , _4800_ ,	
9600 (Default) , _19200_ ,	
57600	
PARITY Values <OPT>	
NONE (Default) , EVEN, ODD	
DATA Values <OPT>	
8 (Default) , _7_	
STOP Values <OPT>	
1 (Default) , _2_	
DTR Values <OPT>	
OFF (Default) , ON	
TERM Values <OPT>	
OFF (Default) , ON	

IO.HW

Path	Description
H.WARE <ul style="list-style-type: none"> L IO.HW L FRC.OUT L TST.IN L DB.1..8 L DB.9..16 L DB.17..24 L DB.25..32 	<p>FRC.OUT (Force Outputs): used for testing and fault finding to force the IO on and off.</p> <ul style="list-style-type: none"> • UP and DOWN keys to select the output. • +/- key to switch the output on and off. <p>TST.IN (Test Inputs): use this when testing and fault finding to check the status of IO when used as inputs.</p> <ul style="list-style-type: none"> • Inputs are listed for each module in order of lowest to highest IO number. '1' means the input is active, '0' means the input is inactive. • UP and DOWN keys to select the module to view. <p>DBNC (Debounce): sets the amount of debouncing for inputs, in milliseconds [ms].</p>
<p>DBNC Values <NUM></p> <p>1..250 ms</p> <p><i>Default: 50 ms</i></p>	

ANL.HW

Path	Description
H.WARE <ul style="list-style-type: none"> L ANL.HW L TYPE L CLIP L FRC.OUT L ANL.CAL L ADJ.LO L ADJ.HI 	<p>TYPE (Analogue Output Type): sets the analogue output to current (4-20mA) or voltage (0-10V) mode.</p> <p>CLIP (Analogue Output Clip Enable):</p> <p>ON - the output is restricted to 4-20mA or 0-10V.</p> <p>OFF - the output can go at least 3mA or 0.5V beyond these limits.</p> <p>FRC.OUT (Force Analogue Output): sets the number of data bits for the port.</p> <p>ADJ.LO(Calibrate Analogue Output): calibrate 4mA or 0V analogue output. Use the UP and DOWN keys to adjust the calibration.</p> <p>ADJ.HI (Calibrate Analogue Output): adjust 20mA or 10V analogue output. Use the UP and DOWN keys to adjust.</p>
<p>TYPE Values <OPT></p> <p>Current^(Default), Volt</p>	
<p>CLIP Values <OPT></p> <p>OFF^(Default), ON</p>	

6.3. SCALE (Loadcell options and calibration)

BUILD (Scale parameters)

Path	Description
SCALE	Scale Base configuration settings:
L BUILD	TYPE: Range type
L TYPE	SINGLE : Single range
L CABLE	DUAL.I: Dual interval
L DP	DUAL.R: Dual range
L CAP1	CABLE: 6-wire or 4-wire cable termination:
L E1	6-wire: SENSE lines are connected to the instrument.
L CAP2(*)	4-wire: Internal connection between Excitation and SENSE lines is active.
L E2(*)	DP: Set the decimal point position.
L UNITS	CAP1: Sets the fullscale capacity for the scale. If using multiple interval/range, this sets the fullscale capacity of the lowest range/interval.
L HI.RES	E1: Sets the count-by (or resolution) of the scale. If using multiple interval/range, this sets the count-by (or resolution) of the lowest range/interval.
TYPE Values <OPT>	CAP2: If using multiple interval/range, this sets the fullscale capacity of the highest range/interval.
SINGLE ^(Default) , DUAL.I , DUAL.R	E2: If using multiple interval/range, this sets the count-by (or resolution) of the highest range/interval.
CABLE Values <OPT>	UNITS: Sets the weighing units.
6 WIRE ^(Default) , 4 WIRE	None: Units are left blank.
DP Values <OPT>	ARROW.U: Use the top arrow. Units will be printed onto the instrument in the correct location.
000000 ^(Default) 000.000	HI.RES: Sets the scale to high resolution (x10) mode.
00000.0 00.0000	
0000.00 0.00000	
CAP1 & CAP2 Values <NUM>	
100 ..999999 <i>Default: 3000</i>	
<i>Note:</i> Numbers above assume no decimal point.	
E1 & E2 Values <OPT>	
1, 2, 5, 10, 20, 50, 100	
UNITS Values <OPT>	
None, kg ^(Default) , lb, t, g, Oz, N, ARROW U, P	
HI.RES Values <OPT>	
OFF ^(Default) , ON	

Quick Start - Software Version 1.x & 2.x

OPTION (Scale options)

Path	Description
SCALE	<p>USE (Trade Use): This setting affects the operation of trade functions. Options are:</p> <p>INDUST: Industrial (no standard)</p> <p>TRADE: Trade mode</p> <p>FILTER: Set the number of seconds of digital filtering.</p> <p>MOTION: Sets the motion detection sensitivity. This setting is given as xd – yt where weight change of more than x divisions in y seconds will trigger motion.</p> <p>Z.RANGE (Range of Zero): Sets the range over which the indicator can zero the scale.</p> <p>Z.TRAC (Zero Tracking): Sets the rate of automatic zero tracking.</p> <p>Z.INIT (Zero on Startup): Enables the zero-on-start-up feature. When enabled, a zero will be performed as part of the instrument start-up procedure.</p> <p>Z.BAND (Zero Deadband): Sets the weight range around zero which will be considered zero for application purposes.</p> <p>EXT.EX (External Excitation): If using an external supply for loadcell excitation this setting enables additional background calibration services. Under normal conditions this feature is not required.</p> <p>R.ENTRY (Rear Entry): Full access via the rear setup button only. This option is only available when the rear setup button has been used to access the menu system</p> <p>TOT.OPT (Totalising Option): Type of weight used with totalising. Gross or net weight should be used if gross and net weights cannot be added into a single total.</p>
L OPTION	
L USE	
L FILTER	
L MOTION	
L Z.RANGE	
L Z.TRACK	
L Z.INIT	
L Z.BAND	
L EXT.EX	
L R.ENTRY	
L TOT.OPT	
USE Values <OPT>	
INDUST ^(Default) , TRADE	
FILTER Values <NUM>	
0.01s..30.00s <i>Default: 0.5s</i>	
MOTION Values <OPT>	
OFF 1.0d – 0.5t	
0.5d – 2.0d – 0.5t	
1.0t ^(Default) 5.0d – 0.5t	
1.0d – 1.0t 0.5d – 0.2t	
2.0d – 1.0t 1.0d – 0.2t	
5.0d – 1.0t 2.0d – 0.2t	
0.5d – 0.5t 5.0d – 0.2t	
Z.RANGE Values <OPT>	
-2 .. 2 ^(Default) , -1 .. 3, -10 .. 10, -20 .. 20	
Z.TRACK Values <OPT>	
Off ^(Default) , Slow, Fast	
Z.INIT Values <OPT>	
Off ^(Default) , On	
Z.BAND Values <NUM>	
0 ^(Default) – full scale	
EXT.EX Values <OPT>	
Off ^(Default) , On	

Quick Start - Software Version 1.x & 2.x

R.ENTRY Values <OPT>	
Off ^(Default) , On	
TOT.OPT Values <OPT>	
Disp ^(Default) , Gross, Net	

CAL (Scale calibration)

Path	Description
SCALE	Calibrate Scale
L CAL	ZERO: Perform a zero calibration.
L ZERO	SPAN: Perform a span calibration. A zero calibration should be done before doing a span calibration.
L SPAN	ED.LIN: Add or Modify linearization points.
L ED.LIN	CLR.LIN: Clear unwanted linearization points.
L CLR.LIN	DIR.ZER (Direct mV/V Zero Calibration): Enter signal strength (in mV/V) of zero calibration directly.
L DIR.ZERO	DIR.SPN (direct mV/V span Calibration): Enter the signal strength (in mV/V) of fullscale directly. No test weights required.
L DIR.SPN	DEF.CAL (Default Calibration): Restore instrument to default factory calibration.
L DEF.CAL	

QA (QA alarm)

Path	Description
SCALE:	Configure the quality assurance feature.
L QA	If active the instrument displays a 'QA DUE' warning after the date limit has expired.
L QA.OPT	QA.OPT: Turn QA feature on or off.
L QA.YEAR	QA.YEAR, QA.MONTH, QA.DAY:
L QA.MONTH	Enter QA expiry date.
L QA.DAY	
QA.OPT Values <OPT>	
Off ^(Default) , On	
QA.DATE Values <NUM>	
2000-01-01 to 2099-12-31	

6.4. FUNC (Special functions)

NUM (Number of special functions)

Path	Description
FUNC L NUM	Sets the number of special functions.
NUM Values <OPT>	
-1-(Default) .. -8-	

SFn: TYPE (Function Types)

Path	Description
FUNC L SFn L TYPE	Sets the function type. PRINT: Trigger a RECORD printout SINGLE: Trigger a single serial weight transmission TEST: Display test PRD.SEL: Select Product/Recipe REM.KEY: Remote Key operation BLANK: Blanking input THUMB: Thumb-wheel Product Selection START: Start batch PAUSE: Pause batching To resume batching press START key again. ABORT: Abort batching PSE.ABT: Long press to abort current batch. To resume batching press START key again. SUSPND: suspend batching REPORT: Trigger a REPORT printout
TYPE Values <OPT>	
NONE (Default)	
PRINT	
SINGLE	
TEST	
PRD.SEL	
REM.KEY	
BLANK	
THUMB	
START	
PAUSE	
ABORT	
PSE.ABT	
SUSPND	
REPORT	

SFn: KEY (Function Key / Remote Input)

Path	Description
FUNC L SFn L KEY	Select front panel key or external input to trigger the special function. All functions that respond to input events have a KEY setting.
KEY Values <OPT>	
None ^(Default) , F1 .. F3, IO1 .. IO32	Functions like THUMB (Thumbwheel) require multiple inputs to function and have an equivalent setting to specify these inputs.

SFn: PRINT (Printing Functions)

Path	Description
FUNC L SFn L TYPE : PRINT L KEY L PRT.OUT L IL.TYPE L I.LOCK	Configuration of the PRINT Special Function. KEY: Select key (function key or external input) to be used for this special function. PRT.OUT (Printout): Selects the printout to be used. Up to four printouts can be configured in the PRINT menu and one selected here, only RECORD type printouts are valid. IL.TYPE (Interlock Type): Sets the type of printing interlock to be used. Options are: MOTION: Printing is enabled every time the scale becomes stable. I.LOCK: Printing is enabled when the weight is stable after a weight movement larger than the interlock weight. RET.Z: Printing is enabled after the scale has returned to zero and is stable at a reading other than zero. I.LOCK (Interlock): Sets the interlock weight that will trigger a print event.
KEY Values <OPT>	
None ^(Default) , F1 .. F3, IO1 .. IO32	
PRT.OUT Values <OPT>	
None ^(Default) , PRINT.1 .. PRINT.2	
IL.TYPE Values <OPT>	
NONE ^(Default) , MOTION, I.LOCK, RET.Z	
I.LOCK Values <NUM>	
0 .. Fullscale	

SFn: SINGLE (Single Serial Output Functions)

Path	Description
FUNC L SFn L TYPE:SINGLE L KEY L AUT.OUT	Single serial outputs are similar to printing but do not support any interlocking or totalising functions. KEY: Function key or external input to use. AUT.OUT: Choose which Auto Output Serial service to trigger. The Auto Output TYPE should be set to SINGLE.
KEY Values <OPT>	
None ^(Default) , F1..F3, IO1.. IO32	
AUT.OUT Values <OPT>	
AUTO.1 ^(Default) , AUTO.2	

SFn: BLANK (Blanking Functions)

Path	Description
FUNC L SFn L TYPE : BLANK L KEY L BLANK	Blanking allows the detection of an external input to block the instrument operation by blanking the screen and blocking key functions. (An example application is for tilt sensing.)
KEY Values <OPT>	KEY: External input to use.
None ^(Default) , F1 .. F3,	BLANK: Set display blanking style:
BLANK Values <OPT>	DASH: Fill instrument display with '-' characters.
DASH ^(Default) , BLANK	BLANK: completely blank instrument display.

**SFn: START, SFn: PAUSE, SFn:ABORT, SFn PSE.ABT, SFn: SUSPND
(Batching Functions)**

Path	Description
FUNC L SFn LTYPE:START, PAUSE,ABORT, PSE.ABT SUSPND L KEY	Batching control functions to start, pause or abort the batching process. KEY: Select key or external input to use for this special function.
KEY Values <OPT>	
None ^(Default) , F1 .. F3, IO1 .. IO32	

SFn: THUMB (Thumbwheel Product Selection)

Path	Description
FUNC L SFn LTYPE : THUMB L IO.BAND	The Thumbwheel function supports the use of an external thumbwheel to select the current product using the product number. A selection of '0' on the thumbwheel enables keyboard selection of the current product.
IO.BAND Values <OPT>	
IO1-4 ^(Default) , IO17-20, IO5-8, IO21-24, IO9-12, IO25-28, IO13-16, IO29-32	IO.BAND: Select which four remote inputs are used for the thumbwheel function.

SFn: REM.KEY (Remote Key Functions)

Path	Description
FUNC L SFn L TYPE : REM.KEY L KEY L FUNC	Remote key functions allow external inputs to be used to trigger instrument key functions. The external 'keys' operate even if the instrument keys are locked and passcodes don't have to be entered.
KEY Values <OPT>	
None ^(Default) , IO1 .. IO32	KEY: External input to use.
FUNC Values <OPT>	BLANK: Set display blanking style:
NONE, ZERO, TARE, _0_, _1_, _2_,.....	DASH: Fill instrument display with '-' characters. BLANK: completely blank display.

SFn: REPORT (Report Functions) :

Path	Description
FUNC L SFn L TYPE : REPORT L KEY L PRT.OUT L CLR.TOT	Configuration of the REPORT Special Function. KEY: Select key (function key or external input) to be used for this special function. PRT.OUT (Printout): Selects the printout to be used. Up to four printouts can be configured in the PRINT menu and one selected here, only REPORT type printouts are valid.
KEY Values <OPT>	
None ^(Default) , F1 .. F3, IO1 .. IO32	CLR.TOT (Clear Totals): Sets whether totals are cleared automatically after print.
PRT.OUT Values <OPT>	
None ^(Default) , PRINT.1 .. PRINT.2	
CLR.TOT Values <OPT>	
NO ^(Default) , ASK, CLEAR	

6.5. SER.NET (Network communications)

Path	Description
FUNC L SER.NET L TYPE L SERIAL L ADDR	Configure the serial networking support. TYPE: Type of Network Protocol: NONE: Disable networking Protocol B: SERIAL: Serial Port to use.
TYPE Values <OPT>	ADDR (Address): Address of instrument (1..31).
NONE, PROTOCOL.B ^(Default)	
SERIAL Values <OPT>	
SER1A ^(Default) , SER2A	
ADDR Values <NUM>	
1 ^(Default) ..31	

6.6. SER.AUT (Automatic transmit)

NUM (Number of Automatic Transmissions)

Path	Description
SER.AUT L NUM	Sets the number of special automatic outputs
Values <OPT>	
-1- (Default) .. -2-	

AUTO.n (Automatic Output Configuration)

Path	Description
SER.AUT L AUTO.n L TYPE L SERIAL L FORMAT L SOURCE L EV.AUTO(*)	<p>These settings for AUTO.1 and AUTO.2</p> <p>TYPE: Sets the transmission rate:</p> <p>SINGLE: A single function key is used to trigger a single transmission. Rate is determined by external input.</p> <p>AUTO.LO: Transmit at 10Hz</p> <p>AUTO.HI: Transmit at 25Hz</p> <p>AUT.TRC: Sends a message for every traceable weight</p> <p>CMD.ENQ: Sends a message every time a ENQ character is received</p> <p>SERIAL: Select Serial port to use.</p> <p>FORMAT: Set data format.</p> <p>SOURCE: Sets the weight data to send:</p> <p>GROSS: Gross weight</p> <p>Net: Net weight</p> <p>Gr.or.Nt: Gross or net weight</p> <p>EV.AUTO: Token string to define data format for CUSTOM transmissions.</p>
TYPE Values <OPT>	
NONE (Default), SINGLE, AUTO.LO, AUTO.HI, AUT.TRC, CMD.ENQ	
SERIAL Values <OPT>	
SER1A (Default), SER1B SER2A, SER2B	
FORMAT Values <OPT>	
FMT.A (Default), FMT.B, FMT.C, FMT.D, FMT.E, FMT.REG, FMT.TRC, CUSTOM	
SOURCE Values <OPT>	
GROSS (Default), NET GR.or.NT	
EV.AUTO * Values <STR>	
Token String (*) Only used with CUSTOM format.	

6.7. PRINT (Printouts)

NUM (Number of printouts)

Path	Description
PRINT L NUM	Sets the number of printouts.
Values <OPT>	
1 (Default) .. 2	

HEADER (Print header)

Path	Description
PRINT L HEADER L FOOTER	Sets the print header and footer.
Values <STR>	
String	

PAGE (Print page options)

Path	Description
PRINT L PAGE L WIDTH L HEIGHT L PG.END	<p>Page settings configure the height and width of the paper and what to do at the bottom of a page.</p> <p>WIDTH: Sets the page width. A setting of zero disables page width checking.</p> <p>HEIGHT: Sets the page height. A setting of zero disables page height checking.</p> <p>PG.END (Page End String): Sets the string to print at page end. This option allows a cut character, form feed, etc, to be added every page.</p>
WIDTH Values <NUM>	
0 .. 250 <i>Default: 0</i>	
HEIGHT Values <NUM>	
0 .. 250 <i>Default: 0</i>	
PG.END Values <STR>	
Token String	

SPACE (Print blank space options)

Path	Description
PRINT L SPACE L TOP L LEFT L BOTTOM	<p>Space controls the amount of white space to leave around the printout.</p> <p>TOP: Sets the number of blank lines to add at the top of each page.</p> <p>LEFT: Sets the number of spaces to add at the beginning of each line.</p>
Values <NUM>	
0 .. 10	

Quick Start - Software Version 1.x & 2.x

<i>Default: 0</i>	BOTTOM: Sets the number of blank lines to add to the bottom of each page.
-------------------	--

PRINT.n ... (Printout options)

Path	Description
PRINT L PRINT.n L TYPE L FORMAT L SERIAL L NAME L CUSTOM * L REC.PRN <i>or</i> L SER.ST** L SER.END** L BAT.ST L BAT.END L FILL L DUMP L PULSE L WAIT L ABORT <i>or</i> L REP.ST L REP.PR L REP.MAT L REP.END	Each printout has its own format settings. TYPE: Sets the printout type. RECORD is used to print weight at an instance BATCH used within or at the end of the batching process to report on batching and material totals against targets. REPORT used to print data on grand totals (since they were last cleared). FORMAT: Sets the printout format. SERIAL: Select Serial port to use. NAME (Printout Name): Report printouts are available by name to the operator. CUSTOM: For custom printing, each type of printout uses event strings as follows: RECORD: REC.PRN (Record Print): defines entire printout. BATCH: BAT.ST (Event Batch Start) defines what is printed at the start of a batch. BAT.END (Event Batch End) defines what is printed at the end of a batch. FILL (Event Fill Stage) defines what is printed at end of a fill stage. DUMP (Event Dump Stage) defines what is printed at end of a dump stage. PULSE (Event Pulse Stage) defines what is printed for a pulse stage WAIT (Event Wait Stage) defines what is printed for a wait stage ABORT (Event Abort) defines what is
TYPE Values <OPT>	
NONE <small>(Default)</small> , RECORD, BATCH, REPORT	
FORMAT Values <OPT>	
FMT.A <small>(Default)</small> , FMT.B CUSTOM	
SERIAL Values <OPT>	
SER1A <small>(Default)</small> , SER2A	
NAME Values <STR>	
6 character String	

Quick Start - Software Version 1.x & 2.x

CUSTOM Values <STR>	
<p>* Active token strings depend on the TYPE setting</p> <p>** Only available when a number of batches are being run.</p>	<p>printed when a batch is aborted.</p> <p>SER.ST ** (Event Series Start) defines what is printed at the start of a series of batches.</p> <p>SER.END ** (Event Series End) defines what is printed at the end of a series of batches.</p> <p>REPORT:</p> <p>REP.ST (Report Start) defines start of report.</p> <p>REP.PR (Report Product) controls the information printed for each product/recipe (currently only one).</p> <p>REP.MAT (Report Material) defined information printed for each material.</p> <p>REP.END (Report End) defines the end of the report.</p>

6.8. SETP (Setpoints)

NUM (Number of setpoints)

Path	Description
SETP L NUM	Sets the number of special setpoints
Values <OPT>	
1 (Default) ... _8_	

SETP1 ... SETP8 (Setpoint options)

Path	Description
SETP L SETP _n L TYPE L OUTPUT L LOGIC L ALARM L SOURCE (*) L SCOPE (**) L HYS (**) L MASK (***)	Configure the operation of each setpoint. TYPE determines the function of the setpoint. Options are: NONE : Always inactive ON: Always active OVER: active if weight over target UNDER: active of weight under target COZ: active if Centre of Zero ZERO: active if weight is zero NET: active if net weight selected MOTION: active if weight unstable ERROR: active if error conditions detected TOL: active if out of tolerance
TYPE Values <OPT>	
NONE (Default) LGC.AND	

Quick Start - Software Version 1.x & 2.x

<p>ON LGC.OR OVER LGC.XOR UNDER ERROR COZ TOL ZERO PAUSE NET WAIT MOTION RUN FILL</p>	<p>LGC.AND: active if inputs match the bits set in the mask exactly LGC.OR: active if any inputs match the bits set in the mask LGC.XOR: active if only one input matches the bits set in the mask TOL: active if batch out of tolerance PAUSE: active if batch paused WAIT: active if batch waiting for dump enable input RUN: active while batch is running (including when batch is paused) FILL: active whenever any filling stage is running</p>
OUTPUT Values <OPT>	
NONE ^(Default) , IO1 .. IO32	OUTPUT specifies which IO to use or the setpoint output.
LOGIC Values <OPT>	
HIGH ^(Default) , LOW	LOGIC: Logic HIGH forces the output to follow the setpoint activity. Logic LOW forces the output to the reverse of the setpoint activity.
ALARM Values <OPT>	
NONE ^(Default) , SINGLE, DOUBLE, FLASH	ALARM: Alarms are triggered when the setpoint is active. Options are: NONE: no alarm SINGLE: single BEEP DOUBLE: double BEEP FLASH: flash display
SOURCE Values <OPT>	
GROSS ^(Default) , NET, GR.or.NT (*)Only available to OVER, UNDER and ZERO setpoints.	SOURCE: Select which weight values the setpoint checks against the target weight. Options are: GROSS: Gross weight always NET: Net weight always GR.or.NT: Gross or Net depending on which one is displayed.
HYS Values <NUM>	
0 to 999999 <i>Default: 0</i> (**)Only for OVER, and UNDER setpoints.	SCOPE: The setpoint target can be set to be identical for all products (GLOBAL) or different for each product (PROD). HYS: Hysteresis defines the amount of weight required for an active setpoint to become inactive again. A value of 0 still allows for 0.5 graduations of hysteresis. MASK: a 24 bit number that is used by the logic setpoints to match IO1..IO24

6.9. BATCH

APP (Applications)

Path	Description
BATCH └ APP	Set of predefined batching configurations for initial menu setup. The options vary the number of materials (FILL stages) and speeds.
APP Values <OPT>	
1MAT.1SPD, 1MAT.2SPD, 1MAT.3 SPD, 2MAT.1SPD, 2MAT.2SPD, 2MAT.3SPD, ... 6MAT.1SPD, 6MAT.2SPD, 6MAT.3SPD	Choose an option closest to the application to be programmed and vary settings as required. FILL stages are preset using multiple feeders and auto-flight correction. Each application has a DUMP stage. Extra stages can be inserted or deleted as required. 1MAT.1SPD – 1 material, 1 speed uses one single speed FILL stage and one DUMP stage. 1MAT.2SPD – 1 material, 2 speed uses one FILL stage with two speeds and one DUMP stage. 6MAT.3SPD – 6 materials, 3 speed uses six FILL stages each with three speeds and one DUMP stage.

GEN (General)

Path	Description
BATCH	<p>Start Interlock (ST.ILOCK): Input for start interlock if being used (distinct from FILL stage interlock). If used, batch will not start without this input active.</p> <p>Batch Interlock (B.ILOCK): Input for batch interlock. This input must be on for batching to proceed. If not present the batch is paused automatically.</p> <p>Zero on Start (Z.START): YES – forces automatic zero at start of the batch.</p> <p>Zero Interlock (Z.ILOCK): YES – batch PAUSE.ERROR created if not zero at start of batch. This can be used in conjunction with Z.START.</p> <p>Recipe Check (REC.CHK): YES - START key does not operate unless RECIPE key is pressed first.</p> <p>Auto Start (AUTO.ST): SINGLE: Single batch only CONT: Continuous restart until PAUSE or ABORT by Operator NUM: To allow Operator to specify number of batches through RECIPE key. TIME: batch from start time (TM.STRT) at repeat time (TM.RPT) intervals until the stop time (TM.STOP). If the start and stop times are set to the same value the indicator will batch continuously at the repeat time intervals.</p> <p>Auto-clear Number Batches (NUM.CL): YES automatically clears number of batches at the end of the run of multiple batches.</p> <p>Proportional Control (PROP.TP): This control only affects targets, not in-flight/prelims. Percentage (PC): 5% to 2000%, Proportion (PROP): 0.050 to 20.000</p>
L GEN	
L ST.ILOCK	
L B.ILOCK	
L Z.START	
L Z.ILOCK	
L REC.CHK	
L AUTO.ST	
L NUM.CL	
L PROP.TP	
L PROP.CL	
L TM.STRT	
L TM.RPT	
L TM.STOP	
L USE.PT	
L FLT.AV	
L F.DISP	
L JOG.TGT	
L ABT.ACT	
L ERROR	
L TOL	
L PRT.OUT	
ST.ILOCK Values <OPT>	
NONE(Default), IO1 .. IO32	
B.ILOCK Values <OPT>	
NONE(Default), IO1 .. IO32	
Z.START Values <OPT>	
YES, NO(Default)	
Z.ILOCK Values <OPT>	
YES, NO(Default)	
REC.CHK Values <OPT>	
YES, NO (Default)	
AUTO.ST Values <OPT>	
SINGLE, CONT, NUM	
NUM.CL Values <OPT>	
YES, NO (Default)	

Quick Start - Software Version 1.x & 2.x

PROP.TP Values <OPT>	Total (TOTAL): Total batch weight.
NONE ^(Default) , PC, PROP, TOTAL	Auto (AUTO): Automatically recalculate proportion after first fill stage.
TM.STRT Values <NUM>	Auto-clear Proportion (PROP.CL):
0.00...23.59	YES - Automatically clears proportion to 100% at the end of the batch, or the end of the run if multiple batches.
TM.RPT Values <NUM>	Start Time (TM.STRT): The time to start batching for time based batching.
0.00...12.00	Repeat Time (TM.RPT): The time between batch starts for time based batching.
TM.STOP Values <NUM>	Stop Time (TM.STOP): The time to stop batching for time based batching.
0.00...23.59	Preset Tare (USE.PT): YES if Preset Tare used for each product recipe. The preset tare is set using the RECIPE key and is activated at the start of the batch.
USE.PT Values <OPT>	In-Flight Average (FLT.AV): The number of fill results that are averaged to determine the in-flight setting. (Extreme flight results are not included in the calculation to remove impact of rogue batches when there are more than 5 results averaged) Used with the automatic in-flight correction method.
YES, NO	Fill Display (F.DISP): show either the END target or the REMAINING weight to target when filling.
FLT.AV Values <NUM>	Jogging target (JOG.TGT):
1...100	TARGET: Jogging to continue until target reached.
F.DISP Values <OPT>	TOL.LOW: Jogging to continue until low tolerance reached.
END, REMAINING	Abort Action (ABT.ACT): Action to be taken on the batch being aborted.
JOG.TGT Values <OPT>	TOTAL: to total material and batch quantities for the aborted batch.
TARGET, TOL.LOW	IGNORE: to not include quantities from aborted batches in totals.
ABT.ACT Values <OPT>	Error handling (ERROR): PAUSE to pause batch on system errors, overload or underload with a PAUSE.ERROR prompt
TOTAL, IGNORE	
ERROR Values <OPT>	
IGNORE, PAUSE ^(Default)	
TOL Values <OPT>	
NONE ^(Default) , BEEP, PAUSE	
PRT.OUT Values <OPT>	
NONE ^(Default) , PRINT.1, PRINT.2	

Quick Start - Software Version 1.x & 2.x

	<p>displayed.</p> <p>Tolerance Action (TOL): BEEP: beep and continue PAUSE: to pause batch, PAUSE.TOL prompt displayed</p> <p>Print Out (PRT.OUT): Printout to be used by the batching process.</p>
--	---

MAT (Material)

Path	Description
BATCH L MAT LNAME 1...6	Sets the name of each material to be displayed in the Secondly ID, decimal point can also be used.
NAME Values <STR>	
8 character string	

STAGES

Path	Description
BATCH L STAGES LNUM LSTAGES 1...10 LINSERT LDELETE	<p>Sets the number of STAGES with the option of including their TYPE (this can be altered within the actual STAGE set up also).</p> <p>NUM: To set number of stages.</p> <p>INSERT: A new stage can be inserted within the existing stages, or add at the end (APPEND).</p> <p>To insert a new stage within existing stages, scroll through the stages and select the stage that the new stage is to be before and press <OK>. The type for this new stage can be set after the prompt TYPE?.</p> <p>To insert a new stage at the end, scroll through the stages to APPEND and press <OK>. The type for this new stage can be set after the prompt TYPE?.</p> <p>DELETE: Scroll through stages and press <OK> to delete the stage.</p>
NUM Values <NUM>	
1...10	

STAGE.n:FILL

Path	Description
BATCH	Configuration of a FILL stage.
L STAGES	Outputs – Outputs are active all the time when selected.
L STAGE.n	Slow Fill (S.FILL): Output for slow fill
L TYPE : FILL	Medium Fill (M.FILL): Output for medium fill if used
L S.FILL	Fast Fill (F.FILL): Output for fast fill if used
L M.FILL	Input (INPUT): Input used to end fill stage before target weight is reached.
L F.FILL	Interlock (I.LOCK): Input to use as a filling interlock. This input must be on for filling to proceed. If not present the batch is paused automatically. A single input can be used as the interlock for more than one filling stage.
L INPUT	Stage Output (STG.OUT): Output to identify this stage if used.
L I.LOCK	
L STG.OUT	
L FEEDER	Feeder Control (FEEDER): SINGLE for only one feeder used at any time, MULT to allow multiple feeders at the same time.
L MAT	Material (MAT): Select material for this FILL stage. (Allows the same material to be filled a number of times in the same batch.)
L ST.ACT	Action at Start (ST.ACT): Automatic action at the start of this FILL stage.
L CORR	
L DLY.ST	
L DLY.CHK	
L DLY.END	
L JOG.ON *	
L JOG.OFF *	
L JOG.SET *	
L MAX.SET *	
L SCP.FLT **	
L SCP.TOL **	
L DIRN	
S.FILL Values <OPT>	
IO1..IO32	Correction (CORR): Type of correction to be used at the end of this fill stage.
M.FILL Values <OPT>	
NONE ^(Default) , IO1..IO32	Manual (MAN.FLT): Uses in-flight as set by operator only.
F.FILL Values <OPT>	
NONE ^(Default) , IO1..IO32	Jogging (JOG): Jog using in-flight as set by operator.
INPUT Values <OPT>	
NONE ^(Default) , IO1..IO32	Auto Flight (AUT.FLT): Uses the average in-flight (as set up in the BATCH:GEN) and no jogging.
I.LOCK Values <OPT>	
NONE ^(Default) , IO1..IO32	Auto Jog (AUT.JOG): Uses the average in-flight (as set up in the BATCH:GEN) and jogging.
STG.OUT Values <OPT>	
NONE ^(Default) , IO1..IO32	Delay Timers to add a time delay within this stage.
FEEDER Values <OPT>	Delay Start (DLY.ST): occurs at the start of this stage.
SINGLE, MULT	Delay End (DLY.END): occurs at the end of this stage.
	Hold-Off-Check (DLY.CHK): stops any weight

Quick Start - Software Version 1.x & 2.x

MAT Values <OPT>	<p>checks after a decision has been made concerning the outputs. For example when fast fill changes to slow fill, or when the dump output is first turned on.</p> <p>Jog Timing: To control jogging, times are set for how long the Slow Fill output is ON and OFF.</p> <p>Number of jogs in a set (JOG.SET): Specifies how many 'jogs' (Slow Fill ON then OFF) are performed before the instrument waits for no motion. If target not reached the process will repeat as necessary.</p> <p>Maximum number of jog sets (MAX.SET): Specifies the maximum number of jog sets that should be attempted to reach the target, a setting of 0 is unlimited jog sets.</p> <p>In-flight scope (SCP.FLT): Use global or per-product settings for in-flight values.</p> <p>Tolerance scope (SCP.TOL): Use global or per-product settings for high and low tolerance values.</p> <p>Fill direction (DIRN): Sets if weight should increase or decrease while filling.</p>
1..6	
ST.ACT Values <OPT>	
NONE ^(Default) , TARE, GROSS	
CORR Values <OPT>	
JOG, MAN.FLT, AUT.JOG AUT.FLT	
DLY.ST, DLY.END Values <NUM>	
0.0 ^(Default) ..18,000.0s	
DLY.CHK Values <NUM>	
0.0 ^(Default) ..60,000.0s	
JOG.ON, JOG.OFF Values <NUM> *	
0.1 ^(Default) ..60.0s	
JOG.SET Values <NUM> *	
1..20	
MAX.SET Values <NUM> *	
0..20	
SCP.FLT Values <OPT> **	
PROD ^(Default) , GLOBAL	
SCP.TOL Values <OPT> **	
PROD ^(Default) , GLOBAL	
DIRN Values <OPT>	
W.IN ^(Default) , W.OUT	
(*) NB only available with JOG and AUT.JOG	
(**) NB only available with v2.x software	

STAGE.n:DUMP

Path	Description
BATCH	Hardware:
L STAGES	Output (DMP.OUT): Output to be used for dump signal.
L STAGE.n	Stage (STG.OUT): Output to identify this stage
L TYPE : DUMP	Tolerance (ON.TOL): Sets if dump stage will run if the batch is in or out of tolerance.
L DMP.OUT	Dump Interlock input (I.LOCK): If used, this input signal must be present for the dump stage to continue to operate.
L STG.OUT	Dump Enable (ENABLE): This input is both edge and level sensitive and must be detected for the dump stage to proceed.
L ON.TOL	Dump Type (DMP.TYP): Can dump for a given length of TIME or to a given WEIGHT if non zero.
L I.LOCK	Correction (CORR): Only available if dump type is weight.
L ENABLE	JOG to using jogging correction at the end of a dump to weight.
L DMP.TYP	Delay Timers to add a time delay within this stage.
L CORR	Delay Start (DLY.ST): occurs at the start of this stage.
L DLY.ST	Delay End (DLY.END): occurs at the end of this stage.
L DLY.CHK	Hold-Off-Check (DLY.CHK): stops any weight checks after a decision has been made concerning the outputs. For example when fast fill changes to slow fill, or when the dump output is first turned on.
L DLY.END	Jogging options are only available when dumping to WEIGHT with correction of JOG.
L JOG.ON	Jog Timing: To control jogging, times are
L JOG.OFF	
L JOG.SET	
L TOL.HI	
L PLS.TME	
DMP.OUT Values <OPT>	
IO1..IO32	
STG.OUT Values <OPT>	
NONE ^(Default) , IO1..IO32	
ON.TOL Values <OPT>	
BOTH ^(Default) , IN, OUT	
I.LOCK Values <OPT>	
NONE ^(Default) , IO1..IO32	
ENABLE Values <OPT>	
NONE ^(Default) , IO1..IO32, F1, F2, F3	
DMP.TYP Values <OPT>	
WEIGHT ^(Default) , TIME	
CORR Values <OPT>**	
NONE ^(Default) , JOG	
DLY.ST, DLY.END Values <NUM>	

Quick Start - Software Version 1.x & 2.x

<p>0.0..18,000.0s</p> <p>DLY.CHK Values <NUM></p>	<p>set for how long the Slow Fill output is ON and OFF.</p> <p>Number of jogs in a set (JOG.SET): Specifies how many 'jogs' (Slow Fill ON then OFF) are performed before the instrument waits for no motion. If target not reached the process will repeat as necessary.</p> <p>Dump Target (TOL.HI): Only available when dumping to WEIGHT. Sets maximum weight allowed for dump completion.</p> <p>Pulse Time: Only available when dumping to TIME. Sets number of seconds dump output is pulsed.</p>
<p>0.0..60,000.0s</p> <p>JOG.ON, JOG.OFF Values <NUM>*</p>	
<p>0.1..60.0s</p> <p>JOG.SET Values <NUM>*</p>	
<p>1..20</p> <p>TOL.HI Values <NUM>**</p>	
<p>0...99,999</p> <p>PLS.TME Values <NUM>***</p>	
<p>0.10..18,000.00s</p> <p>Note: (*) only available with JOG (**) only available when WEIGHT type selected (***) only available when TIME type selected</p>	

STAGE.n: PULSE

Path	Description
BATCH	A stage to pulse an output where the pulse duration settable by an operator.
L STAGES	
L STAGE.n	NAME: 8 character string to name this PULSE stage and to be displayed in the Secondary ID.
L TYPE : PULSE	
L NAME	
L PLS.OUT	Hardware
L STG.OUT	Pulse Output (PLS.OUT): The output to be used for the pulse signal.
L INPUT	Stage Out (STG.OUT): Output to identify this stage.
L TIMER	Input (INPUT): The input used to finish the pulse stage. If NONE is selected, the instrument will wait for START or OK key. If IGNORE is selected, the timer will be used instead.
L PROMPT	
L ST.ACT	
L DLY.ST	
L DLY.END	
L SCP.PLS	
L LINK	
NAME <STR>	
1..8 characters	
PLS.OUT Values <OPT>	
IO1..IO32	Timer (TIMER): Use or ignore timer for pulse stage. If set to ignore the input will be used instead.
STG.OUT Values <OPT>	
NONE ^(Default) , IO1..IO32	Prompt (PROMPT): 9 character string to be shown on Secondary Display.
INPUT Values <OPT>	
NONE ^(Default) , F1..F3, IO1..IO32, IGNORE	Start Action (ST.ACT): Automatic action at the start of this PULSE stage.
TIMER Values <OPT>	
USE ^(Default) , IGNORE	Delay Timers
PROMPT Values <STR>	
1..9 characters	Delay Start (DLY.ST): Delay to occur at the start of the PULSE stage.
ST.ACT Values <OPT>	
NONE ^(Default) , TARE, GROSS	Delay End (DLY.END): Delay to occur at the end of the PULSE stage.
DLY.ST, DLY.END Values <NUM>	
0 ^(Default) ..18,000s	Pulse scope (SCP.PLS): Sets if the pulse timers are set globally or per-product.
SCP.PLS Values <OPT> *	LINK: Used to repress PULSE if previous or next fill or dump stages are not run.
GLOBAL ^(Default) , PROD	Note:
LINK Values <OPT>	(*) only available with v2.x software
NONE ^(Default) , PREV, NEXT	

6.10. ANL.OUT (Analogue Output)

Path	Description
ANL.OUT	<p>Configures the operation of the analogue transmission.</p> <p>ABS (Absolute Weight): Transmit negative weight values the same as positive weight values.</p> <p>SOURCE: GROSS, NET, GR.or.NT</p> <p>RANGE: Set the weight range. Options are:</p> <p>FULLSCALE: 0 to full scale</p> <p>CUSTOM: Use WGT.LO and WGT.HI</p> <p>WGT.LO (Weight Low): Weight corresponding to the lower analogue limit. (e.g. 0V or 4mA)</p> <p>WGT.HI (Weight High): Weight corresponding to the higher analogue limit. (e.g. 10V or 20mA)</p>
L ABS	
L SOURCE	
L RANGE	
L WGT.LO	
L WGT.HI	
ABS Values <OPT>	
NO ^(Default) , YES	
SOURCE Values <OPT>	
GROSS ^(Default) , NET GR.or.NT	
RANGE Values <OPT>	
FULLSCALE ^(Default) , CUSTOM	
WGT Values <NUM> *	
-999999 .. 999999	
*only available when RANGE is CUSTOM	

6.11. End (Save and exit)

7. Accessory Modules

7.1. General

Up to four (4) accessory modules can be plugged into the rear of the instrument to provide additional features such as:

- power supply options, e.g. mains power or batteries
- communications ports, e.g. RS485 networking
- analogue outputs, e.g. 4-20mA or 0-10V
- digital inputs and digital outputs, e.g. external buttons or setpoint outputs

The slots on the rear of the instrument are marked as 1, 4, 5 and 6 (note 2 and 3 are not available).

CAUTION Instrument should be switched off before connecting or disconnecting accessory modules.

7.2. Installation and configuration

Basic steps for installation of modules:

- Check instrument switched off.
- Connect module. Refer to the specific module manual for wiring details.
- Switched instrument on.
- Enter safe setup or full setup.
- Go to applicable area in setup menu and allocation functions to hardware as required.
- Review hardware allocation and test.

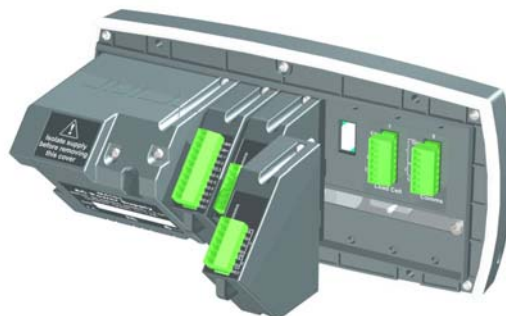

7.3. Input/Output Configuration

Inputs/outputs are provided using accessory modules, such as the M4301, M4302 and M4401. Some modules provide I/O which can be inputs or outputs depending on configuration. The I/O range for each module is given in the module manual. For example, M4301 is IO1 to IO8 and M4302 is IO17 to IO20.

7.3.1. Inputs

Three assignable keys are built into the indicator (F1..F3) and they can be configured as certain types of inputs, in addition to module inputs.

Various inputs are specified in the special functions (FUNC) and batching (BATCH) sections of the setup. Some example inputs within the setup menu are shown below.

<p>FUNC</p> <ul style="list-style-type: none"> L NUM (1..8) L SF_n L TYPE L KEY L 	<p>BATCH</p> <ul style="list-style-type: none"> L GEN L ST.ILOCK L 	<p>BATCH</p> <ul style="list-style-type: none"> L STAGES L STAGE.n1 <ul style="list-style-type: none"> L TYPE : FILL L L I.LOCK L L STAGE.n2 <ul style="list-style-type: none"> L TYPE : PULSE L L INPUT
---	---	---

Debounce can be customised in H.WARE:IO.HW.

7.3.2. Outputs

Various outputs are specified in the set points (SETP) and batching (BATCH) sections of the setup.

Up to 8 setpoint outputs can be specified by type and physical output. Each type of batching stage allows for a number of outputs. Some example outputs within the setup menu are shown below.

<p>BATCH</p> <ul style="list-style-type: none"> L STAGES L STAGE.n L TYPE : DUMP L DMP.OUT L STG.OUT L I.LOCK L ENABLE 	<p>BATCH</p> <ul style="list-style-type: none"> L STAGES L STAGE.n L TYPE : PULSE L NAME L PLS.OUT L STG.OUT 	<p>SETP</p> <ul style="list-style-type: none"> L NUM (1..8) L SETPn L TYPE L OUTPUT L LOGIC L ALARM L SOURCE (*) L SCOPE(**) L HYS(**)
---	---	---

These setup menus are discussed further in 6.9 BATCH page 38 and 6.7 PRINT (Printouts) page 34.

7.4. Analogue Output

Accessory module M4401 provides an analogue output. Currently the instrument supports a single analogue output. It is configured with settings in H.WARE and ANL.OUT. A type of voltage or current output must be selected.

<p>H.WARE</p> <ul style="list-style-type: none"> L ANL.HW L TYPE L CLIP L FRC.OUT L ANL.CAL <ul style="list-style-type: none"> L ADJ.LO L ADJ.HI 	<p>ANL.OUT</p> <ul style="list-style-type: none"> L ABS L SOURCE L WGT.LO L WGT.HI
--	--

These setup menus are discussed further in ANL.OUT (Analogue Output) page 47 and 6.2 H.WARE (Hardware Configuration & Test) page 21.

7.5. Communications

There are several accessory modules which provide additional communications ports. Examples are M4201, M4202 and M4203.

Configuration parameters are divided into hardware (e.g. baud rate or parity) and application (e.g. auto transmit format or networking) settings.

H.WARE	SER.AUT	FUNC
L SER1.HW L BAUD L PARITY L DATA L STOP L DTR L TERM L SER2.HW L BAUD L PARITY L DATA L STOP L DTR L TERM	L AUTO. <i>n</i> L TYPE L SERIAL L FORMAT L SOURCE L EV.AUTO ^(*)	L SER.NET L TYPE L SERIAL L ADDR

These setup menus are discussed further in 6.2 H.WARE (Hardware Configuration & Test) page 21, page 33 and 6.4 FUNC (Special functions) page 27.

8. Hardware Testing

8.1. Overview

Indicator hardware can be checked using settings in the H.WARE menu. Overall hardware allocation is reviewed and clashes noted in the ALLOC menu. The status of inputs can be checked (TST.IN) and outputs forced (FRC.OUT) using items in the IO.HW menu. When an analogue card is fitted, the output can be set also for testing purposes.

8.2. Check Hardware Allocation

Overall hardware allocation can be reviewed within H.WARE:ALLOC. This will display any special functions allocated to the function keys, the communications hardware setup and each IO allocation on each module. For each item its serial number and location (eg. slot number for modules) is displayed by using the +/- key.

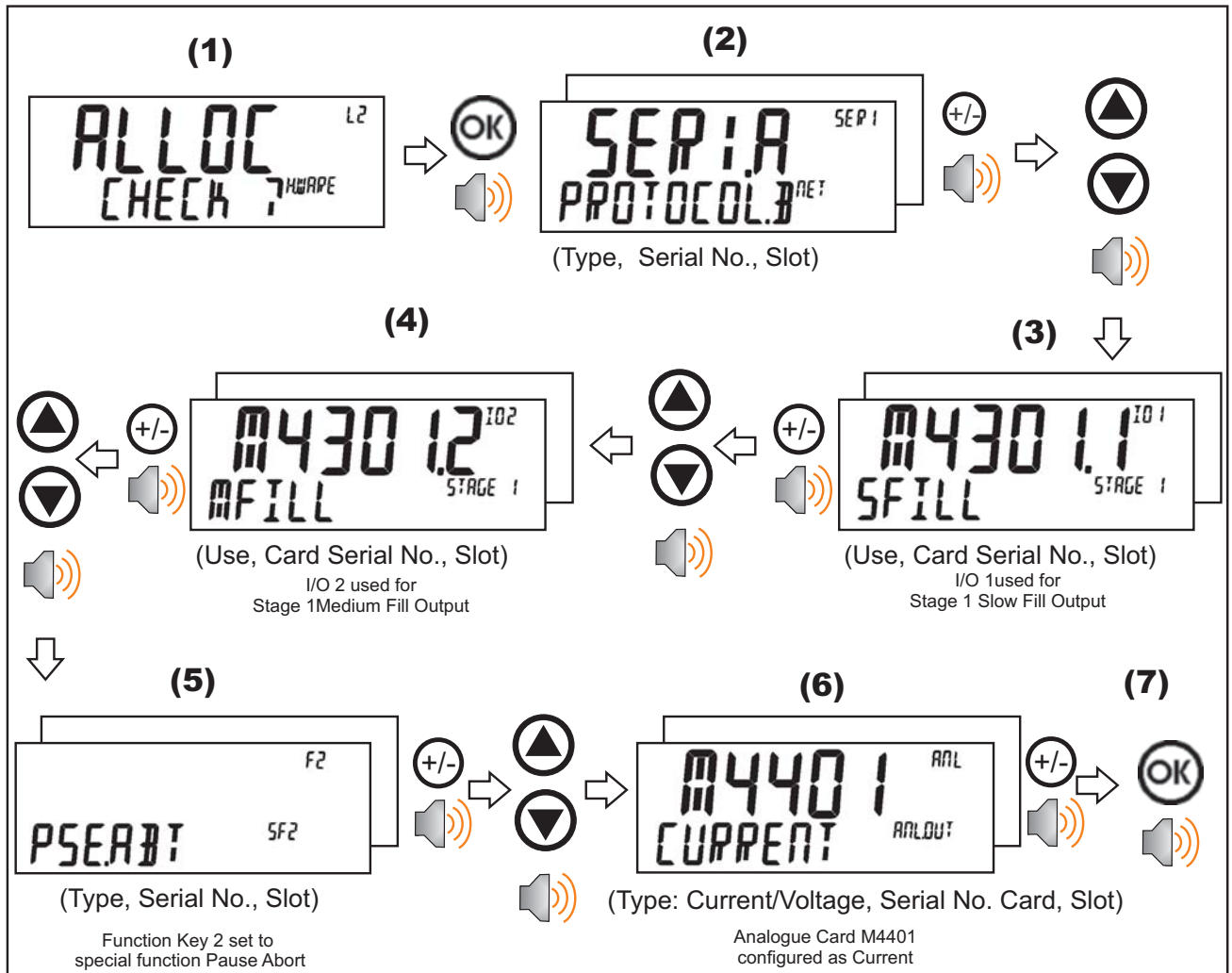

IO Clashes

If an item of hardware has been allocated to more than one function either a CHECK or CLASH prompt will be displayed.

CHECK means that the indicator will function correctly; however, the setup is unusual and should be checked. For example, IO1 has been configured as a stage output in 2 stages.

CLASH means that the indicator cannot function as configured and the setup should be changed. For example, F1 has been configured as a print key and a blanking input.

8.3. Check Inputs

The status of inputs can be reviewed using HD.WARE:OI.HW:TST.IN. This function displays the input status of a block of eight (8) IO.

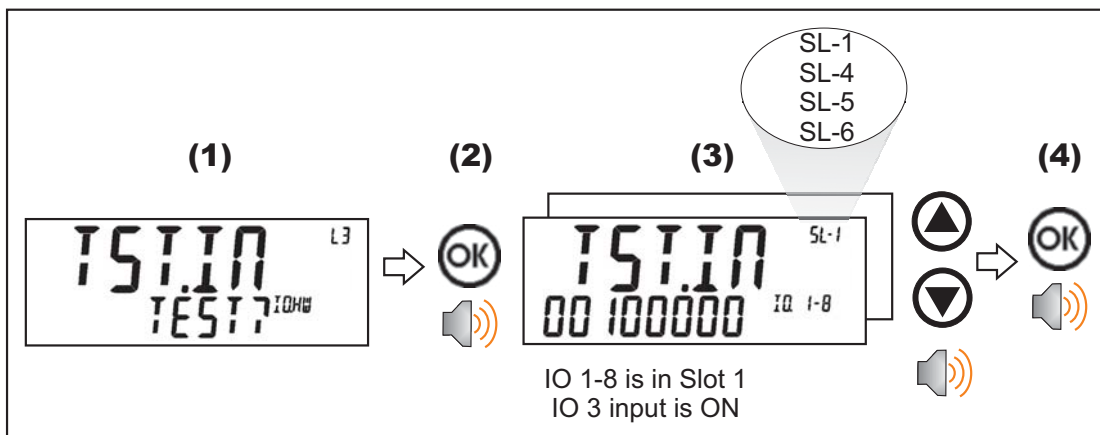

8.4. Force Outputs

An output can be forced using HD.WARE:IO.HW:FRC.OUT.

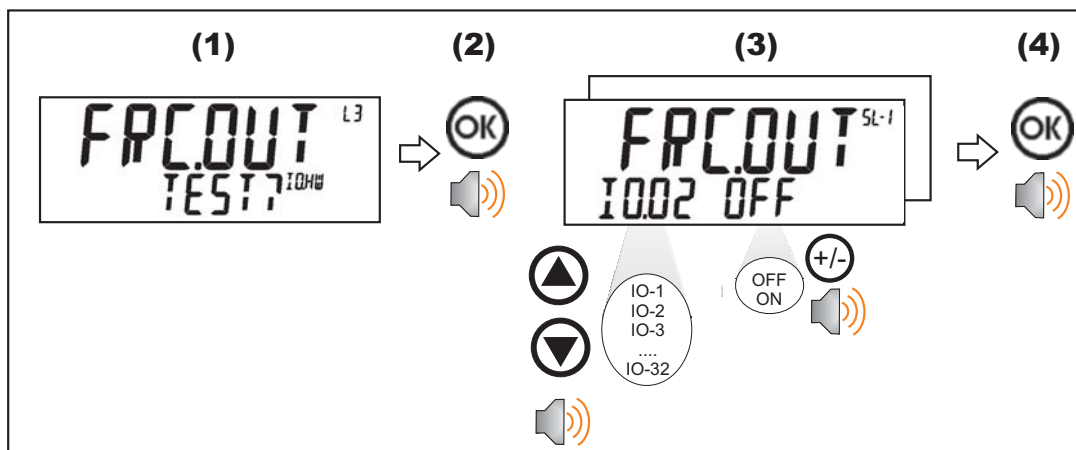

8.5. Force Analogue Output

An analogue output, voltage or current can be driven using HD.WARE:ANL.HW:FRC.OUT for testing purposes.

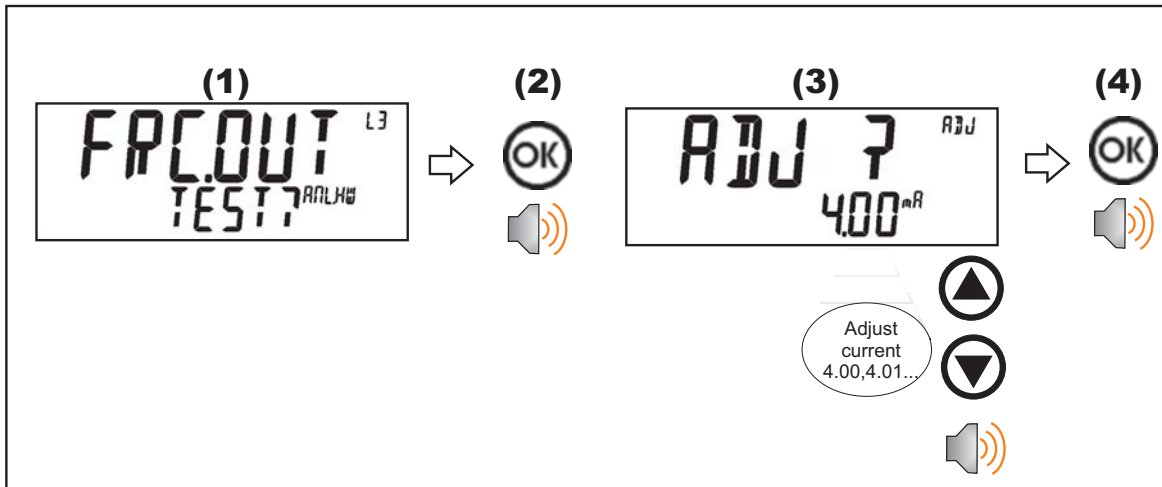

8.6. Check Load Cell Hardware

The mV/V reading of the load cell can be viewed along with the number of times it has been overloaded in HD.WARE:LC.HW:MVV and OL.CNT.

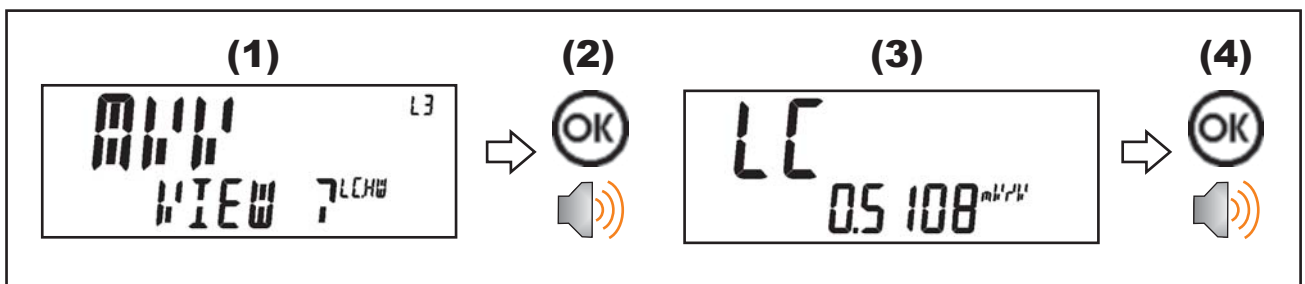

9. Error Messages

9.1. Overview

Error messages may be displayed to warn of operation outside of the acceptable limits. Short messages (XXXXXX) will appear as a single message. Longer messages (XXXXXX) (YYYYYY) will appear on the display in two parts, first the (XXXXXX) part, then the (YYYYYY) part.

9.2. Weighing Errors

These messages show status messages or errors that may occur during normal weighing operation.

Error	Description	Resolution
(U.LOAD)	The weight is below the minimum allowable weight reading.	Increase the weight or decrease the minimum allowable weight reading.
(O.LOAD)	The weight is above the maximum allowable weight reading. Warning - overloading may damage mechanical scale elements.	Check the condition of load cell connections. Check for damaged load cell.
(ERROR) (RANGE)	The weight reading is beyond the limit set for Zero operation. The operation of the <ZERO> key is limited in the setup during installation. The indicator cannot be Zeroed at this weight.	Increase the Zero Range (Z.RANGE) or use the <TARE> key instead.
(ERROR) (MOTION)	Scale motion has prevented a <ZERO> or <TARE> operation from occurring on command.	Try the operation again once the scale is stable.
(ERROR) (ADC)	An error with the ADC has prevented a <ZERO> or <TARE> operation from occurring	Ensure load cell cabling is correct.

9.3. Setup Errors

These messages show status messages or errors that may occur during the instrument setup.

Error	Description	Resolution
(ENTRY) (DENIED)	When accessing setup, more than three attempts have been made with the incorrect passcode.	Turn the instrument off. When the instrument is turned back on, enter the correct passcode to access setup.
(WR DENIED) (RD DENIED)	The instrument may be in Safe Setup and an item that needs Full Setup has been selected for editing.	Access Full Setup to access this item.

9.4. Calibration Errors

Following are a list of the possible error messages that may be displayed to warn of failed or incorrect calibration:

Error	Description	Resolution
(FAILED) (BAND)	An attempt has been made to calibrate with a weight or signal which is not in the valid range.	Check weights and retry.
(FAILED) (ERROR)	An attempt has been made to calibrate while the scale signal is not valid.	Check loadcell connection and the 4-wire/6-wire setting.
(FAILED) (TIMEOUT)	For an unknown reason, the calibration was unable to complete.	Retry.
(FAILED) (RES)	An attempt has been made to calibrate the scale to a resolution which is too high for the instrument.	Check weights and retry.
(FAILED) (TOO CLOSE)	An attempt has been made to add a linearisation point too close to zero, span or another linearisation point.	Check weights and retry.

9.5. Pause Conditions

The following table lists the possible pause messages that may be displayed due to the condition noted.

Pause Msg	Description	Resolution
"OPER"	Operator pause via function key	Press Start when ready
"OLOAD", "ULOAD"	Paused due to an overload or underload error having occurred.	Take action as required for error then press Start to restart batching.
"ERROR"	System error present or ADC operation failed for some reason	Take action as required to resolve the error. Press Start to restart batching.
"TOL"	Paused because out of tolerance on Fill stage. This only occurs if the option (Pause on out of tolerance) is enabled.	Take action as required. Press Start to restart batching.
"ILOCK"	Paused because interlock condition not met (start, fill, dump interlocks)	Activate interlock condition. Press Start to restart batching.
"INFLIGHT"	Pause if fast, medium and slow fills are not set to switch in the correct order, or the in-flight is greater than the fill target.	Using the inflight key, check F.PRE (if used), M.PRE (if used) and FLIGHT. Compare in-flight to fill target. Press Start to restart batching.
"SUSPEND"	Operator suspend via function key press	Press Start when ready

9.6. Diagnostic Errors

The instrument continually monitors the condition of the internal circuits. Any faults or out-of-tolerance conditions are shown on the display as an **E** type error message.

Error	Description	Resolution
(E0001)	The power supply voltage is too low.	Check supply
(E0002)	The power supply voltage is too high.	Check supply
(E0004)	Positive sense voltage out of range.	Check scale connections. Check SCALE:BUILD:CABLE setting.
(E0008)	Negative sense voltage out of range.	Check scale connections. Check SCALE:BUILD:CABLE setting.
(E0010)	Temperature is outside of allowable limits	Check location
(E0020)	Module Error	Replace Module
(E0200)	The calibration information has been lost.	Re-calibrate
(E0400)	The factory information has been lost.	Return for Service
(E0800)	Application settings have been set to defaults.	Check and re-enter application settings
(E2000)	ADC Out of Range Error. This may be caused from a broken load cell cable.	Check SCALE:BUILD:CABLE setting. Check load cell cable, wiring, etc.
(E4000)	The runtime information has been lost.	Check Zero and Tare settings.

Notes

Notes

SMART WEIGHING SOLUTIONS

